

TOERAH

חומש

בראשית

∞  
TORAH

CHUMASH BEREISHIT

*The Book of Genesis*

*Parshat Noach*

*A free excerpt from the Kehot Publication Society's  
new Chumash Breishis/Book of Genesis with commentary  
based on the works of the Lubavitcher Rebbe,  
produced by Chabad of California.*

*The full volume is available for purchase at [www.kehot.com](http://www.kehot.com).*

*For personal use only. All rights reserved.  
The right to reproduce this book or portions thereof,  
in any form, requires permission in writing from  
Chabad of California, Inc.*

*With an Interpolated English Translation  
and Commentary Based on the Works of  
The Lubavitcher Rebbe*

**THE TORAH - CHUMASH BEREISHIT**

WITH AN INTERPOLATED ENGLISH TRANSLATION  
AND COMMENTARY BASED ON THE WORKS OF  
THE LUBAVITCHER REBBE

Copyright © 2008  
by  
Chabad of California

A project of  
**Chabad of California**

741 Gayley Avenue, Los Angeles, CA 90024  
310-208-7511 / Fax 310-208-5811

Published by  
**Kehot Publication Society**

770 Eastern Parkway, Brooklyn, New York 11213  
718-774-4000 / Fax 718-774-2718

**Order Department:**

291 Kingston Avenue, Brooklyn, New York 11213  
718-778-0226 / Fax 718-778-4148  
[www.kehot.com](http://www.kehot.com)

All rights reserved, including the right to reproduce this book  
or portions thereof, in any form, without permission,  
in writing, from Chabad of California, Inc.

The Kehot logo is a trademark  
of Merkos L'Inyonei Chinuch, Inc.

ISBN: 978-0-8266-0190-1  
ISBN: 978-0-8266-0195-2 (set)

*Published in the United States of America*



# חומש בראשית

# THE TORAH

*With an Interpolated English Translation  
and Commentary Based on the Works of  
The Lubavitcher Rebbe  
Rabbi Menachem M. Schneerson*

CHUMASH BEREISHIT

*The Book of Genesis*

*Parshat Noach*



*Kehot Publication Society*

*770 Eastern Parkway, Brooklyn NY 11213*





**GENESIS**

Bereishit

**Noach** 2 נח

Lech Lecha  
Vayeira  
Chayei Sarah  
Toldot  
Vayeitzei  
Vayishlach  
Vayeishev  
Mikeitz  
Vayigash  
Vayechi

**EXODUS**

Shemot  
Vaeira  
Bo  
Beshalach  
Yitro  
Mishpatim  
Terumah  
Tetzaveh  
Ki Tisa  
Vayakheil  
Pekudei

**LEVITICUS**

Vayikra  
Tzav  
Shemini  
Tazria  
Metzora  
Acharei Mot  
Kedoshim  
Emor  
Behar  
Bechukotai

**NUMBERS**

Bemidbar  
Naso  
Beha'alotecha  
Shelach  
Korach  
Chukat  
Balak  
Pinchas  
Matot  
Masei

**DEUTERONOMY**

Devarim  
Va'etchanan  
Eikev  
Re'eh  
Shoftim  
Ki Teitzei  
Ki Tavo  
Netzavim  
Vayeilech  
Ha'azinu  
Vezot Habrachah



# נח Noach

## Overview

In the previous *parashah*, *Bereishit*, we saw how God created the world and gave humanity the mission of transforming it into His home, and how humanity then spurned that mission, abandoning it *en masse*.

This being the case, we would expect the next act in this Divine drama to be the inception of the Jewish people, the nation designated to cultivate Divine consciousness and steer humanity back onto the course of living life in God's presence. The time is seemingly ripe: the stage is set; all the props are in place; there even appears to be a suitable candidate for the protagonist who will serve as the progenitor of this new people: *parashat Bereishit* ends teasingly with the words, "Noah found favor in the eyes of God."<sup>1</sup>

Yet the Torah keeps us in suspense, postponing the genesis of the Jewish people until the next *parashah*. Evidently, some additional groundwork needs to be laid before the world will be ready for the advent of a chosen people. The detailed description of this groundwork is the subject of *Parashat Noach*, which is named after its protagonist. Noah was the man whom God singled out to build the ark, through which human and animal life would be spared from the Flood that would wipe out the incorrigibly iniquitous human race, allowing it to begin anew.

What was this groundwork? What additional steps had to be taken before the world could begin its upward climb toward the birth of the Jewish people and the giving of the Torah at Mount Sinai? To address this question, we first need to take a closer look at the name of this *parashah*, since, as we have already pointed out, the names of the *parashiot* disclose their essential message and lesson.

The word (in this case, the name) *Noach* means "rest" and "tranquility." Yet the events in this *parashah* are anything but restful and tranquil. The cataclysmic flood that ruthlessly and indiscriminately destroys all life on earth is certainly the epitome of upheaval and unrest, as are the two remaining significant episodes of the *parashah*: the cursing of Ham and the forced dispersion of humanity from the Tower of Babel.

However, if we look at the underlying purpose of these incidents and their ensuing results, we can see that the name *Noach* is actually quite fitting. As physically turbulent as the flood may have been, its purpose was to cure the world of the even-more problematic

---

1. Genesis 6:8.

## OVERVIEW OF NOACH

---

spiritual state that necessitated it. The antediluvian world was still relatively young, and all forms of life possessed the full vigor of youth—as evinced most strikingly by the extraordinary human longevity that characterized this era. Yet this strength was brittle: once creatures developed and matured, they became inflexible, almost immutable; it was almost impossible for them to change. This was no less true of the spiritual dimension of life than of the physical dimension: once people’s characters were molded and their modes of behavior formulated, it was extremely difficult for them to change. And since societal norms were all the while becoming increasingly corrupt, the overwhelming majority of humanity became progressively entrenched in a downward spiral of degenerating moral attitudes and behavior.

The Flood changed all this. The battering waters softened the earth not only physically but spiritually, as well, making reality more pliable, more flexible, more receptive to change. The “new world” Noah beheld upon emerging from the ark<sup>2</sup> was one in which the winds of repentance (*teshuvah*) were blowing freely, accessible to all, no matter how chronically unwholesome their behavior might become.

Thus, when God declared after the Flood, “Never again will there be a flood that will destroy the earth,”<sup>3</sup> He was not reconciling Himself to people continuing to sin as they had before, nor was He admitting that by flooding the earth, He had made some kind of blunder that He would never again repeat. Rather, He was saying that by flooding the earth, He altered reality in such a way that it would never again become *necessary* to bring on a flood—not because people’s nature had improved for the better, but because He had now provided them with a novel mechanism that they could use to counteract and even eradicate the effects of negative behavior.

As such, the Flood was a highly significant and crucial step toward achieving the goal of Creation, namely, promoting and disseminating Divine consciousness in the world until it ultimately would be transformed into God’s natural home. It was therefore also a crucial step in laying the groundwork for the genesis of the Jewish people. The message of hope that the Torah is supposed to convey to the world is that it is never too late; that God is always waiting to welcome us back with open arms; and that we can always begin anew, even going on to fulfill our Divine mission with a success we never thought imaginable.

The lesson of this *parashah* remains perennially pertinent to our lives. When we are confronted with a particularly trying situation or turbulent phase in our lives, it would serve us well to recall that, just like the Flood, its purpose is to cleanse and refine us. By following the example of Noah, who did not panic in the face of the impending floodwaters but rather resolutely stood his ground, we can not only come away unscathed from the ordeal but in fact stand to reap the potential benefits inherent within it, even emerging strengthened. By focusing on the opportunity inherent in the challenge rather than on the superficial difficulty with which we are confronted, we transform the destructive floodwaters into “the waters of Noah”<sup>4</sup>—the waters of tranquility and rest.

And if, as was Noah, we are wise enough to use the experience advantageously, we can thereby help transform the whole world into an environment more conducive to Divine consciousness, thus bringing it closer to its ultimate and true fulfillment.<sup>5</sup>

---

2. *Vayikra Rabbah* 30:8. 3. Genesis 9:11. 4. Isaiah 54:9. 5. Based on *Likutei Sichot*, vol. 20, pp. 285-287.

ONKELOS  
9 אֱלֹהִים תּוֹלְדֵת נֹחַ גִּבֹּר וְכֹאִי  
שְׁלֵיִם הָיָה בְּדֹרוֹהֵי בְּדַחֲלֵתָא דִּינִי  
הַלִּיף נֹחַ:

# 6:9 אֱלֹהִים תּוֹלְדֵת נֹחַ גִּבֹּר וְכֹאִי שְׁלֵיִם הָיָה בְּדֹרוֹהֵי בְּדַחֲלֵתָא דִּינִי הַלִּיף נֹחַ:

RASHI

התהלכתי לפניו. נח היה צריך סעד לתומכו, אבל אברהם היה מתחנך ומהלך בצדקו מאליהו: התהלך לשון עבר. והוא שמושו של למד: בלשון כבוד, משמשת להבא ולשעבר בלשון אחר: "קום התהלך" להבא, "התהלך נח" לשעבר. "התפלל בעד עבדיך" להבא, "ובא והתפלל אל הבית הזה" לשון עבר, אלא שהיו"ו שבראשו הופכו להבא:

9 אֱלֹהִים תּוֹלְדֵת נֹחַ גִּבֹּר וְכֹאִי. הוֹאִיל וְהוֹפִירוּ — סֵפֶר בְּשִׁבְחוֹ, שֶׁנֶּאֱמַר: "וְכָר צְדִיק לְכַרְכָּה". דָּבָר אַחֵר: לְלַמֶּדְךָ, שֶׁעָקַר תּוֹלְדוֹתֵיהֶם שֶׁל צְדִיקִים מְעֵשִׂים טוֹבִים: בְּדֹרֵיהֶם. יֵשׁ מִרְבוּתֵינוּ דוֹרָשִׁים אוֹתוֹ לְשִׁבַּח: כֹּל שֶׁכֵּן שָׂאלוּ הָיָה בְּדוֹר צְדִיקִים הָיָה צְדִיק יוֹתֵר. וַיֵּשׁ שְׂדוּרָשִׁים אוֹתוֹ לְגַנְאִי: לְפִי דוֹרוֹ הָיָה צְדִיק, וְאֵלוֹ הָיָה בְּדוֹרוֹ שֶׁל אַבְרָהָם — לֹא הָיָה נֶחֱשֵׁב לְכֻלּוֹם: אֵת הָאֱלֹהִים הִתְהַלֵּךְ נֹחַ. וּבְאַבְרָהָם הוּא אוֹמֵר: "הִתְהַלֵּךְ לְפָנַי", "אֲשֶׁר

1. משלי י, ז. 2. בראשית יז, א. 3. בראשית כד, מ. 4. בראשית יג, יז. 5. שמואל א יב, יט. 6. מלכים א ח, מב.

CHASIDIC INSIGHTS

disparages Noah. The Maggid of Mezerich, however, finds cause to praise Noah even in this context: Since Noah lived in a generation of extremely wicked people, he was unable to elevate them, and moreover, they hampered his own spiritual growth. He was like a person on a rooftop, trying to pull up a heavy load with a rope: if the load is too heavy, the person eventually has to drop the load and is nearly pulled off the roof himself. This is why Noah needed God’s assistance to maintain his righteousness.

In contrast, the people of Abraham’s generation were not as evil. They therefore did not hamper Abraham’s spiritual growth, so he was able to progress without being completely dependent upon God and even influence many of them to join his ranks.

Thus, even in the context of the “disparaging” interpretation, Noah was still righteous and faultless according to his ability under the circumstances. But had he lived in Abraham’s generation, he, too, would have been able to grow in his righteousness on his own.<sup>7</sup>

(Although Noah died when Abraham was fifty-eight, he is not considered to have lived in Abraham’s “gen-

eration,” since it wasn’t until Abraham left Charan at seventy-five that he began to truly influence his generation to think like he did and to thus merit being called “the generation of Abraham.”<sup>8</sup>)

**He lived in corrupt times:** Although Noah was the only righteous person of his generation, this singularity incredibly did not negatively affect him!

This thought can serve to inspire us when a defeatist inner voice taunts us: “Why do you even bother to study the Torah and fulfill God’s commandments at all? After all, you are just one very small person in a very big world that is often cold and even hostile to goodness and holiness.”

The story of Noah provides a fitting response to this defeatist inner voice: Noah resolved to behave properly despite the antagonistic behavior of his contemporaries, and furthermore, his conduct brought salvation to the entire world. If Noah, who was truly on his own, was capable of this, certainly we today, who are *not* alone in our commitment to Torah, should be able to courageously withstand the challenges of our world.<sup>9</sup>

## A CLOSER LOOK

**[9] The Torah first describes his righteousness:** Why doesn’t the Torah describe the righteousness of other outstandingly righteous individuals, such as the patriarchs, immediately after mentioning their names?<sup>10</sup>

In the case of the patriarchs, the Torah need not mention their righteousness immediately upon mentioning their names since it details their righteousness at length throughout the narrative of their lives. However, in the case of Noah, the Torah does not provide us with the details of his righteousness. Even the fact that he indeed carried out God’s com-

mand in building the ark does not necessarily mean he was righteous, since: (a) the purpose of the ark was to save him, and (b) the Torah does not indicate that he went *beyond* what he was commanded to do. It must therefore immediately inform us that he was indeed righteous.<sup>11</sup>

Alternatively, the Torah mentions Noah’s righteousness to teach us the idea of praising the righteous. Once we have internalized this lesson, the Torah need not repeat it each time a righteous person is mentioned.<sup>12</sup>

7. Or Torah (Rimzei Torah), Noah 6a. 8. Likutei Sichot, vol. 20, pp. 13-21. 9. Hitva’aduyot 5743, vol. 1, pp. 412-413. 10. See Gur Aryeh and others. 11. Likutei Sichot, vol. 5, pp. 37-38, note 14. 12. Likutei Sichot, vol. 28, p. 136, note 40.

## The Flood

**6:9 The following are the descendants of Noah.** Inasmuch as Noah alone was destined to perpetuate the lineage of the human race that began with Adam, the Torah begins a new history of humanity from him.<sup>1</sup> But before enumerating his offspring, the Torah first describes his righteousness, in order to explain why God singled him out to be spared from the impending flood and to demonstrate that our true “offspring” are our good deeds:

Even though his life spanned many corrupt generations,<sup>2</sup> **Noah was a righteous man;** he remained **faultless despite** the corruptive influence of **his generations.** Nonetheless, he did not possess sufficient moral fortitude to remain righteous on his own. Rather, in order to remain righteous, **Noah walked with God,** that is, he had to keep his mind constantly focused on Him. Thus, on an absolute scale, he would not have been considered exceptionally righteous; he was **faultless** only **relative to** the corruption of **his generations.**

---

∞ CHASIDIC INSIGHTS ∞

---

**9 The following are the descendants of Noah:** The Torah’s introduction to its account of Noah’s descendants provides us with two lessons in childrearing:

*The Torah first describes his righteousness:* From this we learn that we should articulate our reverence for the special, saintly people who grace our world. It is not enough to *think* about how grateful we are for these people; our children must hear us *talk* about them. At the mere mention of their names, we should start talking about their saintly behavior, just as the Torah does regarding Noah.

In particular, we should articulate our admiration over the fact that they, as Noah was in his time, are “complete” in their saintliness—meaning that it extends to all facets of their lives, even seemingly mundane acts like eating.

*Our true offspring are our good deeds:* From this we learn that we should raise our children to sense that our greatest aspiration for them is that they excel in good deeds, which carry on our lineage in the spiritual sense.

Blessed with such an upbringing, our children will follow the right path in their relationship with God, with their fellow human beings, and especially with their parents. Such an atmosphere will unite the entire family under the common goal of excelling in acts of goodness and kindness.<sup>3</sup>

**The Torah first describes his righteousness:** Speech activates dormant qualities. When we speak negatively about others, it strengthens their negative traits; to an even greater degree, when we speak positively of others, it strengthens their positive qualities.

In light of the above, we see that the purpose of praising the righteous is to affect them positively and give them strength to fulfill their Divine mission. When God Himself praises the righteous, this gives the righteous

enormous strength to fulfill their mission.

This teaches us that we must always try to see the good in others and speak about their good qualities. The result is twofold: we cause the other person’s goodness to be revealed to an even greater degree, and we assist them in fulfilling their Divine mission. Furthermore, by praising others, we elicit God’s blessings, since when our Father looks down upon His children and sees that they love and take care of each other, He is pleased and therefore happily showers His blessings on us.<sup>4</sup>

**He was faultless despite (or relative to) his generation:** These two different ways of reading the verse encourage us to emulate Noah’s attitude toward his milieu, even when we might be inclined to do otherwise:

When feeling spiritually robust, we might argue that we don’t need the protection of “entering the ark,” i.e., immersing ourselves in words of prayer and Torah study, for we do not feel threatened by any raging “floodwaters.” The first way of reading this verse negates this notion, since even the righteous Noah needed to “enter the ark.”

Then there are other times when, like Noah in the second way of understanding this verse, we are righteous only in comparison to those around us. We can then learn from Noah that, despite the “raging waters” threatening us, we nevertheless all have the capacity to save the entire world and ourselves. Our one good deed can tip the scales and cause the world’s merits to outweigh its demerits. Just as Noah “beheld a new world” after the Flood,<sup>5</sup> so can we all build a new world.<sup>6</sup>

**He was faultless relative to the corruption of his generations:** This implies that had Noah lived in the generation of Abraham, he would *not* have been considered righteous. Rashi therefore says that this interpretation

---

1. *Likutei Sichot*, vol. 5, p. 42. 2. Nachmanides. 3. *Likutei Sichot*, vol. 9, pp. xiv-xv. 4. *Likutei Sichot*, vol. 5, pp. 45-46. 5. *Bereishit Rabbah* 30:8. 6. *Likutei Sichot*, vol. 5, pp. 282-283.



**10 Noah was the father of three sons: Shem**, who would play the most pivotal role in the ensuing history of humanity; **Ham**, the youngest; and **Japheth**, the oldest.<sup>13</sup>

**11** As recounted above, by the year 1536, **the world had become corrupt before God**, with idolatry and licentiousness rampant,<sup>14</sup> and in addition, **the land was filled with robbery**.

**12 God saw the world, and it was corrupt, for all flesh**—even the animals—**had perverted its way on the earth** by engaging in cross-species relations.

**13** In that year, **God said to Noah, “I have decided to put an end to all flesh**, for several reasons: Firstly, many of them are guilty of idolatry and licentiousness, and this type of indiscriminate behavior incurs the corrective response of indiscriminate destruction. Nonetheless, these two transgressions by themselves would not be enough to seal their fate; it is **because the world is filled with robbery due to them that I shall obliterate them from the earth**. True, many of them are below the age of 100 and thus cannot be held legally culpable,<sup>15</sup> but society has degenerated to the point where there is no longer any hope that they will turn out righteous at a later stage.<sup>16</sup> Even though I am not going to destroy the world in its entirety, I will wipe out the top layer of earth—as deep as can be reached by a plow—to express how their malevolent behavior almost made Me regret having created the world in the first place.<sup>17</sup>

**14** Of all the ways at My disposal to spare you from this destruction, I want you to **make yourself an enormous ark**. Perhaps when everyone sees what you are doing and asks you about it, the news of the impending flood will inspire them to repent. You are to build it out in the open, and I want you to build it yourself, without any help from your sons or anyone else; this way it will take you a long time to build, giving your contemporaries ample time to consider repenting.<sup>18</sup> Make the ark **out of cypress wood**, for the word for ‘cypress’ (*gofet*) is related to the word for ‘sulphur’ (*gofrit*), and the floodwater will be sulfurous,<sup>19</sup> a fact that might further encourage the people to repent. **You shall make the ark with compartments** for each type<sup>20</sup> of animal, **and you shall caulk it inside and outside with pitch**. It will be necessary to caulk it both inside and out because the floodwater will hit it forcefully.

---

❧ CHASIDIC INSIGHTS ❧

---

**14 I want you to build it yourself:** God could have easily allowed Noah’s sons to help him build the ark, or even have allowed him to hire outside workers. But this would have accelerated the ark’s completion, which would have run counter to its purpose. God knew that

Noah was not terribly interested in saving his contemporaries from destruction, for he did not pray for them at all.<sup>21</sup> The only way Noah would encourage his fellows to mend their evil ways if commanded to do so—and even then, only in order to discharge his obligation

❧ INNER DIMENSIONS ❧

**[10] Shem, Ham and Japheth:** Noah’s sons are not listed according to the order of their birth but rather in the order of the root of their souls:

Shem is rooted in the right axis of the ten *sefirot*,

the axis of kindness; Ham in the left axis, that of strength and severity; and Japheth in the middle, the axis of harmony.<sup>22</sup>

---

13. Above, 5:32. 14. Above, 6:1-4. 15. See on 1:28, above. 16. Implied in *Likutei Sichot*, vol. 5, p. 40, note 28. 17. Above, 6:6. *Likutei Sichot*, vol. 35, pp. 72-73. 18. *Likutei Sichot*, vol. 15, pp. 34-36. 19. See *Likutei Sichot*, vol. 10, p. 35. 20. *Likutei Sichot*, vol. 25, p. 29, note 16. 21. *Zohar* 1:67b ff, 254b, 3:14b ff. 22. See *Zohar* 1:73a; *Or HaTorah, Bereishit*, vol. 3, p. 595a, cited in *Likutei Sichot*, vol. 10, p. 28.

ONKELOS

15 וְדִין דְּתַעֲבִיד וְתֵהּ תֵּלֵת מֵאָה אֲמִין אֲרַבָּא דְּתַבּוּתָא חֲמִשִּׁין אֲמִין פּוּתִינָה וְתִלְתִּין אֲמִין רּוּמָה: 16 נְהוּר תַּעֲבִיד לְתַבּוּתָא וְלֵאמָתָא תִּשְׁכַּלְלָנָה מִלְּעֹלָא וְתִרְעָא דְּתַבּוּתָא בְּסִטְרָה תִּשּׁוּי מְדוּרִין אֲרַעָאין תִּנְגִּין וְתִלְתִּיאין תַּעֲבִידָנָה:

15 וְזֶה אֲשֶׁר תַּעֲשֶׂה אֹתָהּ שְׁלֹשׁ מֵאוֹת אַמָּה אַרְבֶּה הַתְּבָה חֲמִשִּׁים אַמָּה רַחְבָּהּ וּשְׁלֹשִׁים אַמָּה קוֹמָתָהּ: 16 צְהַר | תַּעֲשֶׂה לַתְּבָה וְאֶל-אַמָּה תִּכְלֶנָה מִלְּמַעְלָה וּפְתַח הַתְּבָה בְּצַדָּהּ תִּשֶׂים תַּחְתִּים שְׁנַיִם וּשְׁלֹשִׁים תַּעֲשֶׂה:

RASHI

כְּדֵי שְׂיוּבוּ הַמַּיִם לְמִשְׁהָ: בְּצַדָּהּ תִּשֶׂים. שְׁלֹשׁ וּפְלוּ הַגִּשְׁמִים בָּהּ: תַּחְתִּים שְׁנַיִם וּשְׁלֹשִׁים. שְׁלֹשׁ עֲלִיּוֹת זו עַל גַּב זו: עֲלִיּוֹנִים לְאָדָם, אֲמִצְעִים לְמְדוּרָה, תַּחְתִּים לְזָבֵל:

16 צְהַר. יֵשׁ אוֹמְרִים: חֲלוּן, וְיֵשׁ אוֹמְרִים: אָבֶן טוֹבָה הַמְאִירָה לָהֶם: וְאֵל אַמָּה תִּכְלֶנָה מִלְּמַעְלָה. כְּסוּיָהּ מְשַׁפֵּעַ וְעוֹלָה עַד שְׁהוּא קֶצֶר מִלְּמַעְלָה וְעוֹמֵד עַל אַמָּה,

CHASIDIC INSIGHTS

surprise and puzzle us.

This is what it means to make a window: to break through the façade of nature and allow “Divine light” to enter, and to recognize that, beneath the façade of independence and self-sufficiency, nature is nothing more than God’s tool.

*Luminous stone:* Once we make the window and allow supernatural Godly light to permeate our awareness, we attain an even higher perspective: we learn to see nature *itself* as an object of light and revelation. In the

first stage, we look *past* the façade of nature and see that it is God who creates and sustains nature, but the façade itself continues to seemingly contradict the truth. In the second stage, the façade *itself* serves as a revelation of Divinity. For example, as we will see later,<sup>28</sup> nature’s consistent behavior is a reflection of God’s immutability.

This is alluded to by the “luminous stone”: A “stone,” which appears to be a lifeless and dim inanimate object, becomes a “luminous” source of revelation.<sup>29</sup>

INNER DIMENSIONS

[continued...] *Deed:* Through our holy deeds in performing the commandments, we draw Divine light into the world of *Asiyah* (the world of deed).<sup>30</sup>

**Its width 50 cubits:** Noah embodies the “male” *sefirot* of *chochmah* and *Z’eir Anpin*, whereas the ark embodies the “feminine” *sefirot* of *malchut* and *binah*. Hence the ark’s width is fifty cubits, corresponding to the “fifty gates of *binah*.”<sup>31</sup> It is particularly the *width* that alludes to *binah*, since *binah* develops and adds “width” to the concentrated essence of *chochmah*. Corresponding to these two elements of the ark, Noah’s name appears twice in the opening verse of this *parashah*, alluding to the two elements within Noah, *chochmah* and *Z’eir Anpin*, which he was to bring to the ark in order to unify *chochmah* with *binah* and *Z’eir Anpin* with *malchut*.

“Entering the ark” in our lives translates as acquiring understanding (*binah*) of the Torah, and accepting the kingdom (*malchut*) of Heaven by fulfilling the commandments. The commandments are related to *malchut* because they must be performed in total submission and selflessness, like a servant in the presence of his king. Torah study, in contrast,

is related to *binah* because it must be studied with understanding and self-awareness.<sup>32</sup>

[16] **A lower deck, a second deck, and a third deck:** In their spiritual parallel, these three decks correspond to the three general dimensions of the soul as well as to the three general dimensions of the spiritual worlds from which the dimensions of the soul derive:

Level of the Ark	Dimension of the Soul	Spiritual World
lower deck	<i>nefesh, ruach, and neshamah</i>	<i>Beriah, Yetzirah, and Asiyah</i>
second deck	<i>chayah</i>	<i>Atzilut</i>
third deck	<i>yechidah</i>	<i>Adam Kadmon</i>

As the soul descends, becomes submerged in the “floodwaters” of this world, and then enters the spiritual ark of prayer, it not only does not drown, it is uplifted, as was Noah’s ark.<sup>33</sup> This elevation occurs to all aspects of the soul, paralleled in the three decks of the ark, up to and including even the highest level, *yechidah*.<sup>34</sup>

28. On 8:21, below. 29. *Likutei Sichot*, vol. 10, p. 23; *Sichot Kodesh 5731*, p. 195. 30. *Or HaTorah, Bereishit*, vol. 3, 639b. 31. *Rosh HaShanah 21b*. 32. *Sefer Ma’amarim 5742*, pp. 47-52. 33. See 8:4, below. 34. *Likutei Sichot*, vol. 20, p. 296 and note 26, citing *Or HaTorah*, citing Rabbi Moshe Zacut.

**15 This is how you shall make it: The length of the ark shall be 300 cubits (144 meters, or 471 feet), its width 50 cubits (24 meters, or 77 feet), and its height 30 cubits (14.4 meters, or 47 feet).**

**16** Even though you will naturally build the ark with numerous windows and stock it with enough lamps to provide light, I want it to be especially well-lit.<sup>26</sup> **You shall therefore make an additional skylight and use a luminous stone for additional light in the ark. Taper the roof so that its tip is one cubit wide, so the water will run off it. Place the entrance to the ark in its side, so the water won't seep in from above. You shall make it with a lower deck for garbage, a second deck for the animals, and a third deck for the people.**

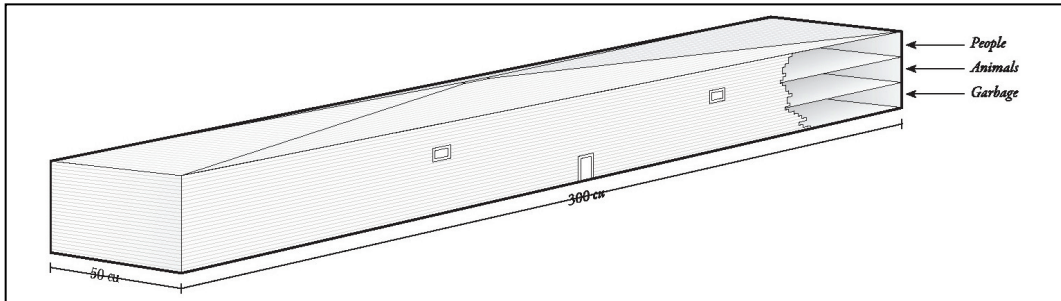

Figure 6: The Ark

#### ✧ CHASIDIC INSIGHTS ✧

**16 A skylight and a luminous stone:** A window creates no light of its own; it simply allows existing outside light to enter. A luminous stone, on the other hand, is in itself a source of light.

Metaphorically, creating light for the ark means bringing Divine consciousness into a world that obscures Divinity. This is achieved in two stages:

*Skylight:* The first step is to pierce through the façade of nature, which obscures God's presence and makes it appear as if the world is independent from God. The truth is that God is very involved in the world; we can often sense the hand of God at work in the "coincidences" that occur in our lives.<sup>27</sup> But in order to see God's presence clearly, we must first see past the veil of

nature that obscures it.

We must also train our children from a young age to view miracles as the "norm" and nature as "unnatural." Young children have not yet been "indoctrinated" by the façade of nature and can still be educated in the reality of the supernatural. The latter reality should be so tangible to them that, instead of finding miracles mysterious, they find nature mysterious! How can such a thing as "nature" exist in God's world? How can the physical be of more overriding importance than the spiritual? How can empty, brute strength prevail over purity and holiness? How can it be difficult to follow the Torah's precepts? If the world is, after all, God's creation, then it is nature, and not miracles, that should

#### ✧ INNER DIMENSIONS ✧

**[15] The length of the ark shall be 300 cubits:** The generation of the Flood damaged and corrupted the three worlds of *Beriah*, *Yetzirah*, and *Asiyah* [but not the world of *Atzilut*]. Noah was therefore commanded to build an ark whose length was 300 cubits, corresponding to the three worlds, each world comprising ten *sefirot* that further subdivide into 100 sub-*sefirot*. By entering this ark, he would rectify those three worlds.

In our own lives we rectify the three worlds through

holy thoughts, speech, and deeds:

*Thought:* Through our holy thoughts during prayer, Torah study, and contemplation on the meaning of the commandments, we draw Divine light into the world of *Beriah* (the world of thought).

*Speech:* Through our holy words spoken during Torah study, prayer, and reciting the blessings over the commandments, we draw Divine light into the world of *Yetzirah* (the world of speech).

26. *Likutei Sichot*, vol. 10, pp. 21-23. 27. See *Hayom Yom*, 7 Tishrei.

— ONKELOS —  
 17 וְאָנֹכִי הָאֵל אֲנִי מִיָּמֵי יְת טוֹפְנָא  
 מִיָּא עַל אֲרָעָא לְחַבְלָא כָּל בְּשָׂרָא  
 דִּי בַּהּ רוּחָא דְחַיֵּי מִתְחַזֵּת שְׁמִיָּא  
 כָּל דִּי בְּאֲרָעָא יָמוּת: 18 וְאֶקִּים  
 יְת קִנְיִי עִמָּךְ וְתִיעוּל לְתַבּוּתָא  
 אִתָּ וּבְנִיךְ וְאִתְתָּךְ וְנִשִּׁי בְנִיךְ עִמָּךְ:  
 19 וּמִכָּל דְּחַי מִכָּל בְּשָׂרָא תִרְיוֹן  
 מִכָּל תַּעֲל לְתַבּוּתָא לְקִיָּמָא עִמָּךְ  
 דְּכַר וְנִקְבָּא יְהוֹן:

17 וְאֲנִי הִנְנִי מֵבִיא אֶת־הַמָּבּוּל מִיָּם עַל־הָאָרֶץ לְשַׁחַת  
 כָּל־בְּשָׂר אֲשֶׁר־בּוֹ רוּחַ חַיִּים מִתַּחַת הַשָּׁמַיִם כָּל אֲשֶׁר־  
 בָּאָרֶץ יָגוּעַ: 18 וְהִקְמַתִּי אֶת־בְּרִיתִי אִתְּךָ וּבֵאתָ אֵל־  
 הַתֵּבָה אִתָּהּ וּבְנֵיךָ וְאִשְׁתְּךָ וְנִשְׁי־בְנֵיךָ אִתְּךָ: 19 וּמִכָּל־  
 הַחַי מִכָּל־בְּשָׂר שָׁנִים מִכָּל תֵּבָיָא אֶל־הַתֵּבָה לְהַחֲיָת  
 אִתְּךָ זָכָר וְנִקְבָּה יְהִיוּ:

— RASHI —

מבול: 18 וְהִקְמַתִּי אֶת בְּרִיתִי. בְּרִית הָיָה צָרִיךְ עַל  
 הַפְּרוֹת שְׁלֵא יִרְקְבוּ וְיַעֲפֹשׂוּ, וְשְׁלֵא יִהְרָגוּהוּ רְשָׁעִים  
 שְׁבִדוֹר: אִתָּהּ וּבְנֵיךָ וְאִשְׁתְּךָ. הָאֲנָשִׁים לְבָד וְהַנְּשִׁים  
 לְבָד. מִכָּאן, שֶׁנֶּאֱסָרוּ בְּתַשְׁמִישׁ הַמַּטָּה: 19 וּמִכָּל הַחַי.  
 אֶפְלוּ שְׂדִים: שָׁנִים מִכָּל. מִן הַפְּחוּת שֶׁבָּהֶם לֹא פָּחַתוּ  
 מִשָּׁנִים, אֶחָד זָכָר וְאֶחָד נִקְבָּה:

17 וְאֲנִי הִנְנִי מֵבִיא. הִנְנִי מוֹכֵן לְהַסְפִּים עִם אוֹתָם  
 שְׁזוֹרוּנֵי וְאָמְרוּ לְפָנַי כְּבָרִי: "מִה אֲנֹשׁ כִּי תִזְכְּרוּנוּ":  
 מִבּוּל. שְׁבַלָּה אֶת הַכֹּל, שְׁבַלְבֵּל אֶת הַכֹּל, שֶׁהוּבִיל אֶת  
 הַכֹּל מִן הַגְּבוּהָ לְנִמוּךְ, וְזֶהוּ לְשׁוֹן אֲנָקְלוֹס שֶׁתִּרְגַּם:  
 "טוֹפְנָא" — שֶׁהִצִּיף אֶת הַכֹּל וְהִבְיִאֵם לְכַבֵּל שֶׁהָיָא  
 עֲמוּקָה, לְכַף נִקְרָאת "שְׁנַעֲר" שֶׁנִּזְעְרוּ שָׁם כָּל מַתִּי

13. תהלים ח, ה.

— CHASIDIC INSIGHTS —

nonetheless his actions might serve as an inappropriate example for future generations. Rabbi Yitzchak therefore "criticizes" Noah, not because he was at fault, but to discourage us from emulating Noah's behavior. In this light, we can assume that Noah himself would welcome this critique, since it transforms his otherwise blameworthy behavior into a positive didactic tool.<sup>47</sup>

Before the Flood, the concept of repentance was extremely foreign. Although Adam and Cain managed to repent, we can attribute this to their having been born in the Garden of Eden. Moreover, while there were some individuals who were righteous, the majority was wicked and did not repent. Thus, although Noah rebuked his contemporaries who mocked him,<sup>48</sup> he did not succeed in inspiring them to repent. Methuselah and Enoch also tried to inspire the masses to repent<sup>49</sup> but apparently were unsuccessful, since only Noah and his family were saved from the Flood.

This resistance to repentance and character refinement was due to the coarseness of the physical world at that time. After the Flood, Noah "saw a new world,"<sup>50</sup> meaning a world that had been purified and refined to the point where repentance was no longer only a remote possibility.

This explains why Noah did not pray for his contemporaries nor seek to judge them favorably: in order to judge another person favorably, one has to have gone through a similar experience of failure and repentance. Thus, the Ba'al Shem Tov once caused one of his stu-

dents to arrive at his court just prior to the onset of the Sabbath, almost making him desecrate it. This allowed him to taste the difficulty of keeping the Sabbath and thereby enabled him to judge favorably those whose observance of the Sabbath was lacking in some way.<sup>51</sup> Indeed a true judge—and this is how the Messiah will judge—takes into consideration the background and causes of a crime, not just the crime itself.

Noah, however, had never experienced the terrible temptations his contemporaries had, and therefore could not fathom a person not obeying the word of God. He had never fallen and repented, since repentance did not yet exist. He therefore did not judge them favorably or pray for them.<sup>52</sup>

Today, however, we have no excuse to behave as Noah did, to "don a fur coat," so to speak, to protect ourselves from the cold winds of the world. We must light a fire that not only provides warmth for ourselves, but also for everyone else around us and, indeed, for the entire world.<sup>53</sup>

**19 Of all living beings and of all flesh:** Metaphorically, this teaches us that it is our duty to bring anyone and everyone in danger of spiritually "drowning" into the shelter of our personal, spiritual "ark." The doctrine of Divine Providence implies that when God arranges for us to find out that someone needs help, it is because we are meant to draw him into our lives and bring him closer to Godliness.<sup>54</sup>

47. *Likutei Sichot*, vol. 25, pp. 19-22, *Hitvo' aduyot* 5743, vol. 1, p. 446. 48. *Sanhedrin* 108ab. 49. *Sefer HaYashar*, cited in *Torah Sheleimah* on Genesis 5:32. 50. *Bereishit Rabbah* 38. 51. See also *Igrot Admor HaRayatz*, vol. 3, p. 379. 52. *Hitvo' aduyot* 5721, vol. 1, pp. 158-161. 53. See *Likutei Sichot*, vol. 3, p. 880; *Igrot Kodesh*, vol. 22, p. 118. 54. *Likutei Sichot*, vol. 1, p. 10.

**17 And as for Me**, I am ready to agree with those angels who opposed the creation of humanity.<sup>35</sup> **I am about to bring the Flood of water upon the earth, to destroy from under the heavens all flesh that has in it a breath of life.** The water will cause total disorder and disarray, and everything will rot. The surface of the earth will remain submerged underwater for one full year.<sup>36</sup> **Everything on earth shall perish.**

**18 But I shall establish My covenant with you:** I promise you that the food that you bring with you into the ark will not rot during the entire time that you are in it, and that the people will not kill you when they find out what you are doing. **You and your family shall enter the ark**, but men and women are to live in separate quarters: **you will be together with your sons, and your wife will be with your sons' wives.** It is not appropriate to engage in marital relations while the earth is being destroyed. The animals will likewise not be allowed to mate in the ark.<sup>37</sup>

**19 Of all incorporeal living beings**—the demons,<sup>38</sup> **and of all flesh, you shall bring a minimum<sup>39</sup> of two of each species into the ark to keep alive with you; they shall be male and female.**

---

∞ CHASIDIC INSIGHTS ∞

---

**17 A flood:** The word for “flood” (*mabul*) is related to the word for “confusion” (*balal*).<sup>40</sup> Metaphorically, the waters of the flood drown us, along with our minds, by confusing us as to what is primary and what is secondary in life. The truth is that the purpose of the soul’s descent into this world is to fulfill its Divine mission. Furthermore, the soul’s relationship to material matters, such as eating, is also a part of that mission since, as Maimonides writes, keeping the body healthy is a religious obligation. But when the soul is confused, the awareness of its true mission becomes submerged and forgotten. We then go about our material lives “soul-less,” lacking Divine meaning and purpose.<sup>41</sup>

**18 You and your family shall enter the ark:** The *Zohar*<sup>42</sup> cites two opinions regarding Noah’s failure to pray for his generation: Rabbi Yehudah says that, unlike Moses, who prayed for the worshippers of the Golden Calf, Noah had no righteous forebears in whose merit his prayers would be accepted. He therefore cannot be faulted for not having prayed for his generation. Rabbi

Yitzchak, however, criticizes Noah and maintains that Noah should nevertheless have prayed for them.

It seems strange that Rabbi Yitzchak would criticize Noah’s behavior when he could have justified it, as Rabbi Yehudah did. After all, we are enjoined to always judge others favorably.<sup>43</sup> Furthermore, if the Torah (in its instruction to Noah!) takes pains to not even speak disparagingly of a non-kosher animal, how much more so in regard to a human being. Similarly troubling is the opinion of Rabbi Yochanan in the Talmud, who interprets the phrase “faultless in his generation” to mean that he was only righteous relative to his contemporaries but would have been considered as naught in the days of Abraham. Given the option of interpreting the phrase positively, i.e., that he was righteous *despite* the corruption of his generation, why does he indeed interpret it negatively?

The answer is that, although Noah cannot actually be faulted for being less righteous than Abraham, since the corruption of his time impeded his spiritual growth,

∞ A CLOSER LOOK ∞

**[18] It is not proper to engage in marital relations while the earth is being destroyed:** This applies any time that a calamity, such as a famine,<sup>44</sup> befalls a community. However, a childless couple *is* permitted to try to procreate even during times of calamity. Why, then, were Noah’s *children*, who were childless at the time, prohibited from procreating? The

answer is that, since the world and all the planets were in a “frozen” state, God knew that they would not become pregnant. We are told, in fact, that although the dog, the raven, and Ham transgressed this prohibition and *did* cohabit with their mates,<sup>45</sup> there is no record of any offspring having been born in the ark.<sup>46</sup>

---

35. Above, 1:26. 36. Rashi on 8:14, below. 37. Rashi on 8:17, below. 38. Above, 1:30. 39. See below, 7:2. 40. See below, 11:9. 41. *Sefer HaMa’amarim* 5745, pp. 218-219. 42. *Zohar* 1:67b. 43. *Avot* 1:6. 44. *Ta’anit* 11a; *Y. Ta’anit* 1:6. 45. *Sanhedrin* 108b. 46. *Reshimot*, vol. 3, pp. 41-42.

ONKELOS

20 מעופא לְוַהֲוִי וּמִן בְּעִירָא לְוַהֲוִי וּמִכַּל רְחֵשָׁא דְאַרְעָא לְוַהֲוִי תְרִין מִכְּלָא יַעֲלוּן לְוַתָּךְ לְקִמְנָא: 21 וְאַתָּה סַב לָךְ מִכָּל מִיכַל דְּמִתְאַבֵּל וְתִכְנֹשׁ לְוַתָּךְ וִיהִי לָךְ וְלַהוֹן לְמִיכַל: 22 וְעַבְד נֹחַ כָּכַל דִּי פִקֵּד יְתָה יְיָ בֵּן עֶבֶד: 7:1 וְאָמַר יְיָ לְנֹחַ עוֹל אֶתְּ וּכְל אֲנִשׁ בֵּיתְךָ לְתַבּוּתָא אֲרִי יִתָּךְ חַוִּיתִי וְכֹאֵי קִדְמִי בְּדָרָא הֲדִין: 2 מִכָּל בְּעִירָא דְכִיתָא תִּסַּב לָךְ שְׂבָעָא שְׂבָעָא דְכַר וְנוֹקְבָא וּמִן בְּעִירָא דְלִיתָהּא: דְכִנָּא תְרִין דְכַר וְנוֹקְבָא:

20 מִהָעוֹף לְמִינֵהוּ וּמִן־הַבְּהֵמָה לְמִינֵהּ מִכָּל רֶמֶשׂ הָאֲרָמָה לְמִינֵהוּ שְׁנַיִם מִכָּל יָבֹאוּ אֵלֶיךָ לְהַחְיֹת: 21 וְאַתָּה קַח־לָךְ מִכָּל־מֵאֲכָל אֲשֶׁר יֵאָכֵל וְאַסַּפְתָּ אֵלֶיךָ וְהָיָה לָךְ וְלָהֶם לְאֹכְלָהּ: 22 וַיַּעַשׂ נֹחַ כְּכֹל אֲשֶׁר צִוָּה אֹתוֹ אֱלֹהִים בֵּן עֲשָׂה:

שני 7:1 ויאמר יהוה לנח בא-אתה וכל-ביתך אל-התבה ביי-אותך ראיתי צדיק לפני בדור הזה: 2 מכל הבהמה הטהורה תקח-לך שבעה שבעה איש ואשתו ומן-הבהמה אשר לא טהרה הוא שנים איש ואשתו:

RASHI

אדם בפניו, וכלו שלא בפניו: 2 הטהורה. העתידה להיות טהורה לישׂראל. למדנו, שלמד נח תורה: שבעה שבעה. כדי שיקריב מהם קרבן בצאתו:

20 מהעוף למינהו. אותן שדבקו במיניהם ולא השחיתו דרכם. ומאליהם באו, וכל שהתבה קולטתו הכניס בה: 22 ויעש נח. זה בנין התבה: 1 ראיתי צדיק. ולא נאמר "צדיק תמים". מכאן, שאומרים מקצת שבוו של

CHASIDIC INSIGHTS

entering the "raging waters" of the world, the liturgy of the Prayer Book has us thank God for returning our souls to us. We thereby recall that the vitality we feel within us stems only from God. Through the other blessings we recite in the morning, we recognize that everything we have—clothing, food, etc.—is constantly being created by God and could otherwise not exist. (Hence the tale of the man who would pray for his food even as it lay before him on his plate—he was praying that God continue to enliven it so that it would still be there when he would bring the fork to his mouth.<sup>63</sup>)

Once we have come to the recognition that: (a) the physical world cannot exist on its own, (b) it requires God to recreate it constantly, and (c) the entire purpose of its existence is to be a home for God, we can enter the world and involve ourselves in its activities without fear of the "raging waters."

Before morning prayers, the world seems to us to exist self-sufficiently, independent of God. Through praying, we come to realize that, in reality, there is no independent existence outside of God. With this realization we are ready to enter the world, since we will then consciously avoid engaging in any activity that does not further the goal of making the world into a home for God, and instead see every moment of our lives as an opportunity to fulfill this mission.<sup>64</sup>

**You and your entire household:** Although we have said that "entering the ark" metaphorically signifies immersing ourselves in the words of Torah study and prayer, this does not imply that we should be oblivious

to the needs of others. We must not be content with our own self-preservation alone. We are obligated to bring our families, our children, and ultimately the entire world into a wholesome, safe haven of Torah study and prayer. The plight of our fellow should give us no rest, for we are all like one organism—if one of us is spiritually ill, we are all affected.<sup>65</sup>

**2 Animals that are not ritually pure:** Instead of referring to the non-kosher animals bluntly as "ritually impure," God refers to them indirectly, as "those that are not ritually pure," thereby adding eight seemingly superfluous letters to the Torah. This teaches us that we, too, should go out of our way to use only clean speech and euphemistic expressions.<sup>66</sup> True, the expression "ritually impure" (*tamei*) appears numerous times in the Torah, but in these instances, the Torah is stating a law, and a law must be stated clearly and unequivocally. Besides, the direct term is not considered negative in such contexts, since the issue is the law and not the impurity. However, in a narrative—even when the narrative serves as the basis for a legal ruling—the euphemism is preferred.

The Kabbalistic explanation of this is as follows: When God first had the *thought* to create the world, it immediately came into existence, but only spiritually. Afterwards, when God *spoke* the words of creation ("Let there be light," etc.), the world came into *physical* existence. The state of the world as it exists spiritually in the realm of thought is called "rest" (*menuchah*). Noah's ark also expressed the concept of rest, as alluded to in

63. Zohar 1:199b. 64. Likutei Sichot, vol. 1, pp. 6-8. 65. Likutei Sichot, vol. 1, pp. 8-10. 66. Rashi citing Pesachim 3b.

**20 From each species of bird, from each species of livestock, and from each species of creature that crawls on the ground, two of each kind will come to you on their own to be kept alive;** you will not have to trap or gather them. Nonetheless, the ark will allow only the animals that did not crossbreed to enter; you are to escort these animals to their designated compartments.

**21 And as for you, take for yourself some of every kind of edible food and gather it in for yourself, so that it shall be for you and for them to eat."**

**22 Noah did everything that God commanded him to do** regarding the construction of the ark **exactly**. Even though he built it alone, he managed, remarkably, to finish it within the allotted 120 years.<sup>55</sup> The people, however, did not repent when they found out why Noah was building the ark. Instead, they vowed that if he would try to enter it once it was finished, they would destroy the ark and kill him.<sup>56</sup> In part, this was due to the fact that the spiritual makeup of the antediluvian world was not very conducive to self-refinement and repentance.<sup>57</sup>

◆ *Second Reading 7:1* So, on the 10<sup>th</sup> of Marcheshvan 1656, **God said to Noah, "Come into the ark, you and your entire household, for it is you that I have seen to be righteous before Me in this generation."** Although the Torah records earlier<sup>58</sup> that Noah was both righteous and faultless, God only praises Noah for his righteousness, for it is not appropriate to enumerate all a person's merits when addressing him directly.

2 God continued, "Since you are acquainted with the teachings of the Torah, you know precisely which animals are ritually pure—i.e., those which will eventually be permissible to the Jewish people as food—and those which are not. **You shall take for yourself seven pairs of every kind of ritually pure animal, each pair consisting of a male and its mate, but take only two of the animals that are not ritually pure, a male and its mate.** You are to take an additional number of ritually pure animals because only these are to be permitted to be offered as sacrifices."<sup>59</sup>

---

∞ CHASIDIC INSIGHTS ∞

---

**1 Come into the ark:** Metaphorically, "entering the ark" refers to entering the words of Torah study and prayer, which serve to protect us from the "flood" of worries that threaten to inundate us. When enveloped

by these letters and words, we are impervious to harm, just as Noah and his family remained completely safe despite the flood that raged outside the ark.

This is why, immediately upon awakening and prior to

∞ A CLOSER LOOK ∞

**[20] Will come to you on their own...**the ark will allow only the animals who did not crossbreed to enter: There were additional miracles that enabled Noah to save the animals. For example, it is totally unnatural for predatory animals to remain constrained in a compartment for a complete year. A regular zoo needs to employ a sizeable staff, both to control the animals and to ensure their safety. The ark, however, was only "staffed" by Noah and his

children, who were constantly occupied with feeding the animals, which was such an enormous and painful burden by itself that they never slept soundly throughout their stay on the ark.<sup>60</sup>

Nonetheless, peace reigned in Noah's ark, a taste of the messianic times in which the wolf will lie peacefully with the lamb.<sup>61</sup> We must assume, then, that the nature of the predatory animals miraculously was transformed during their stay in the ark.<sup>62</sup>

---

55. *Likutei Sichot*, vol. 15, p. 36. 56. Rashi on 7:13, below. 57. *Likutei Sichot*, vol. 15, p. 53. See above, 2:14, 6:7. 58. 6:9. 59. *Likutei Sichot*, vol. 12, p. 26, note 35. 60. See *Sanhedrin* 108b. 61. *Sefer HaMa'amarim Ethalech Liozna*, p. 57; *Or HaTorah, Bereishit*, vol. 3, 6669a, et al. 62. *Likutei Sichot*, vol. 25, pp. 29-30.

— ONKELOS —

3 אף מעופא דשמאי שבועא  
שבועא דכר ונוקבא לקמא  
ורעא על אפי כל ארעא: 4 ארי  
לזמן יומין עוד שבועא אגא מחת  
מטרא על ארעא ארבעין ומיין  
וארבעין לילון ואמחי ית כל  
יקומא די עבדית מעל אפי ארעא:  
5 ועבד נח ככל די פקדה יי: 6 ונח  
בר שית מאה שנין וטופנא הוה  
מניא על ארעא: 7 ועל נח ובגוהי  
ואתתה ונשי בגוהי עמה לתבותא  
מן קדם מי טופנא: 8 מן בעירא  
דכנתא ומן בעירא דלינתא  
דכנא ומן עופא וכל די רחש על  
ארעא: 9 תרין תרין עלו לות נח  
לתבותא דכר ונוקבא כמא דפקד  
יי ית נח: 10 והוה לזמן שבועא  
יומין ומי טופנא הוה על ארעא:  
11 בשנת שית מאה שנין לחיי  
נח בירחא תנינא בשבעת עשרא  
יומא לירחא ביומא הדין אתבועו  
כל מבועי תהומא רבא וכוי  
שמאי אתפתחו:

3 גם מעוף השמים שבועה זכר ונקבה לחיות זרע  
על־פני כל־הארץ: 4 כי לַיָּמִים עוֹד שְׁבַע־הַיָּמִים אֲנֹכִי מִמַּטֵּיר  
עַל־הָאָרֶץ אַרְבַּעִים יוֹם וְאַרְבַּעִים לַיְלָה וּמַחֲיִיתִי אֶת־כָּל־  
הַיְקוּם אֲשֶׁר עָשִׂיתִי מֵעַל פְּנֵי הָאָדָמָה: 5 וַיַּעַשׂ נֹחַ כְּכֹל  
אֲשֶׁר־צִוָּהוּ יְהוָה: 6 וַנַּח בֶּן־שֵׁשׁ מֵאוֹת שָׁנָה וְהַמְבּוּל הָיָה  
מֵימֵם עַל־הָאָרֶץ: 7 וַיִּבֶא נֹחַ וּבָנָיו וְאִשְׁתּוֹ וּנְשֵׁי־בָנָיו אִתּוֹ  
אֶל־הַתֵּבָה מִפְּנֵי מֵי הַמְבּוּל: 8 מִן־הַבְּהֵמָה הַטְּהוֹרָה  
וּמִן־הַבְּהֵמָה אֲשֶׁר אֵינְנָה טְהוֹרָה וּמִן־הָעוֹף וְכֹל אֲשֶׁר־  
רָמַשׂ עַל־הָאָדָמָה: 9 שְׁנַיִם שְׁנַיִם בָּאוּ אֵלֶיךָ אֶל־הַתֵּבָה  
זָכָר וּנְקֵבָה בְּאִשְׁרֵי צִוָּה אֱלֹהִים אֶת־נֹחַ: 10 וַיְהִי לְשִׁבְעַת  
הַיָּמִים וּמֵי הַמְבּוּל הָיוּ עַל־הָאָרֶץ: 11 בַּשָּׁנָה שֵׁש־מֵאוֹת  
שָׁנָה לְחַיֵּי־נֹחַ בַּחֹדֶשׁ הַשְּׁנִי בְּשִׁבְעָה־עֶשְׂרֵי יוֹם לַחֹדֶשׁ  
בַּיּוֹם הַזֶּה נִבְקְעוּ כָּל־מַעֲיֵנוֹת תְּהוֹם רְבָה וְאַרְבַּת הַשָּׁמַיִם  
נִפְתְּחוּ:

— RASHI —

לכד והנשים לכד, לפי שנאסרו בתשמיש המטה, מפני  
שהעולם היה שרוי בצער: **מפני מי המבול**. אף נח  
מקטני אמנה היה, מאמין ואינו מאמין שביבא המבול,  
ולא נכנס לתבה עד שדקדוהו הפנים: 9 **באו אל נח**.  
מאליהו: **שנים שנים**. כלם השוו במנין זה, מן הפחות  
היו שנים: 11 **בחודש השני**. רבי אליעזר אומר: זה  
מרחשון. רבי יהושע אומר: זה אדר: **נבקעו**. להוציא  
מימיהו: **תהום רבה**. מדה כנגד מדה, הם חטאו ב"רבה  
רעת האדם", ולקו ב"תהום רבה":

3 גם מעוף השמים וגו'. בטוהורים הכתוב מדבר, ולמד  
סתום מן המפרש: 4 **כי לימים עוד שבועה**. אלו שבועת  
ימי אבלו של מתושלח הצדיק, שחס הקדוש ברוך הוא  
על פבורו ועבב את הפרענות. צא וחשב שנותיו של  
מתושלח, ותמצא שהם כלים בשנת שש מאות שנה  
לחיי נח: **כי לימים עוד**. מהו "עוד"? זמן אחר, זמן זה  
נוסף על מאה ועשרים שנה: **ארבעים יום**. כנגד יצירת  
הולד, שקלקלו להטריח ליוצרים לצור צורת ממורים:  
5 **ויעש נח**. זה ביאתו לתבה: 7 **נח ובניו**. האנשים

— CHASIDIC INSIGHTS —

structions to the letter; the rest was taken care of by God Himself.

Similarly, if we commit ourselves absolutely and passionately to our Divine mission, and act on that commitment, we will be blessed with miraculous success.

Once, when the Ba'al Shem Tov was raising money for charity, he knocked on the window of a home but then immediately went on his way without waiting for a response. Eventually, the resident of the home came to the Ba'al Shem Tov and gave him a donation. Later, the Ba'al Shem Tov was asked: "If you needed that person's help, why didn't you wait for him to come to the window? And if you didn't need his help, why did you knock on his window?" The Ba'al Shem Tov explained: "God wants us to make a natural 'vessel' for His

blessings. I accomplished this by knocking on the window. However, I had many important things to take care of, and I didn't have time to wait for him to come to the door, ask me what I need, etc. I already had made my vessel, so I was ready to move on to my next task."<sup>72</sup>

**11 In the six hundredth year:** The Zohar interprets this verse as a prophecy: "In the six hundredth year of the sixth [millennium, i.e., around the year 1840, the gates of supernal wisdom and the wellsprings of earthly wisdom will open up. This will prepare the world to be elevated in the seventh [millennium, i.e., the messianic era]."

"Supernal wisdom" refers to the wisdom of the Torah, while "earthly wisdom" refers to secular knowledge.

72. Hitva'aduyot 5745, vol. 1, pp. 517-518; Likutei Sichot, vol. 5, p. 344.

**3 You shall also take seven pairs of the ritually pure birds of the heavens, each pair consisting of a male and its mate, in order to keep its seed alive over the entire face of the earth.**

**4 For today, your only surviving ancestor, Methuselah, died. In another seven days, after the customary seven-day period of mourning for him is over, I will bring rain on the earth. The rain will last for forty days and forty nights, corresponding to the forty days it takes for an embryo to be considered a human being, because the wicked people of the earth caused Me to fashion their illegitimate offspring. With this flood, I will obliterate every being that I have made from the face of the earth."**

**5 Noah did all that God had commanded him** regarding settling the animals in the ark and stocking it with provisions, but he himself tarried at the entrance, because he didn't fully believe that God would actually go ahead and implement His plan.<sup>67</sup>

**6 Noah was in his six hundredth year when the Flood occurred and water covered the earth.**

**7 When it started to rain, Noah, together with his sons, his wife, and his sons' wives, came into the ark, fleeing from the waters of the Flood.**

**8 In contrast, all the animals had already entered the ark before it began to rain: Of the ritually pure animals, and of the animals that are not ritually pure, of the birds, and of all the creatures that crawl on the ground,**

**9 one pair of the ritually impure and seven pairs of the ritually pure, male and female, they had come on their own to Noah into the ark, as God had said when He commanded Noah to enter the ark.**

**10 After the seven days of mourning for Methuselah passed, the waters of the Flood came upon on the earth. During the ensuing forty days, the sun, the moon, the planets, and the stars did not shine, and it was therefore completely dark.**<sup>68</sup>

**11 The flood began in the six hundredth year of Noah's life — 1656 — in the second month, Marcheshvan, on the seventeenth of the month. Because of the gravity of the people's misdeeds, ordinary rain did not suffice to cleanse the earth. Rather, on that day, all the wellsprings of the great abyss burst open and the floodgates of the heavens were opened.**

---

❧ CHASIDIC INSIGHTS ❧

---

his name, Noah (*Noach*, related to *menuchah*, "rest"). Thus all the inhabitants of the ark existed on the plane of "thought," which is why they lived peacefully together.<sup>69</sup>

This is the reason that the ark's non-kosher animals are not referred to as "impure." When in the ark, each animal reverted to its spiritual root, where impurity cannot exist. For example, the terrestrial lion is a non-kosher animal, while its spiritual antecedent is one of the holy beasts of the Divine Chariot!<sup>70</sup>

This, then, is the deeper meaning of the instruction that one should seek to use a clean expression: one should try to see everything as it exists in its pristine state within its spiritual roots.<sup>71</sup>

**9 On their own:** Obviously, the fact that the animals came to the ark on their own was miraculous. It was likewise miraculous that no one was able to prevent Noah from entering the ark and that, as has been mentioned, the animals he sheltered dwelled together peacefully. Noah was only required to fulfill God's in-

---

<sup>67</sup> Rashi on v. 7, below. <sup>68</sup> Rashi on 8:22, below. *Likutei Sichot*, vol. 10, pp. 20-21. <sup>69</sup> See above, on 6:20. <sup>70</sup> Ezekiel 1:10. <sup>71</sup> *Or HaTorah*, vol. 3, p. 1228.

— ONKELOS —  
 12 וַיְהִי מִטְרָא נַחַת עַל אֶרֶץ אֲרָבַעִין יָמִין וְאַרְבָּעִין לַיְלֹון:

12 וַיְהִי הַגֶּשֶׁם עַל-הָאָרֶץ אַרְבָּעִים יוֹם וְאַרְבָּעִים לַיְלָה:

— RASHI —

לילו עמו, שהרי כתיב: "ביום הזה נבקעו כל מעינות", נמצאו ארבעים יום כלים בכ"ח בכסלו, לרבי אליעזר, שהחדשים נמנין בסדרן אחד מלא ואחד חסר, הרי שנים עשר ממרחשון ועשרים ושמונה מכסלו:

12 וַיְהִי הַגֶּשֶׁם עַל הָאָרֶץ. וְלֵהֲלֹךְ הוּא אֹמֵר: "וַיְהִי הַמַּבּוּל?" אֵלָּא, כְּשֶׁהוֹרִידֵן — הוֹרִידֵן בְּרַחֲמִים, שְׂאֵם יְחִזְרוּ יֵהִיו גְּשָׁמֵי בְרָכָה, וּבְשֵׁלָא חִזְרוּ הָיוּ לְמַבּוּל: אַרְבָּעִים יוֹם וָגו'. אֵין יוֹם רֵאשׁוֹן מִן הַמְנִין, לְפִי שְׂאֵין

14, ז, י. 15. פסוק יא.

— CHASIDIC INSIGHTS —

temptation.)<sup>76</sup>

**In the second month, Marcheshvan:** The metaphoric Flood also begins in Marcheshvan. During the month of Tishrei, we spend most of our time in the “ark” of the High Holy Days, Sukot, and Simchat Torah. Only in the following month, Marcheshvan, do we return to our ordinary lives. Although this progression appears to be a spiritual descent, there is, in fact, an advantage to the mundane lives we resume in Marcheshvan, since we fulfill the goal of creating a Divine home in this world specifically by infusing mundane existence with Divine consciousness.<sup>77</sup>

**The wellsprings of the great abyss...the floodgates of the heavens.** As mentioned above, the raging waters of the Flood symbolize the worries that flood a person’s mind. These worries can take two forms:

*The great abyss:* These are worries over *lowly*, material matters, such as finances;

*The floodgates of the heavens:* These are worries over more spiritual and *lofty* matters, such as community service, which impede a person from studying the Torah and fulfilling the commandments. While it is, of course, important to be involved in community service, it must not come at the expense of Torah study and observing the commandments, for it is precisely through observing the commandments that a person connects to God and thereby earns His assistance. Therefore, the argument that we are too busy to perform God’s commandments because we are inundated by the “floodgates of the heavens,” i.e., lofty spiritual matters, would never be put forth by our Divine soul, for the Divine soul would never put forth an argument that contradicts the Torah, which requires us to fulfill the commandments regardless of our inundation with communal matters. When such an argument occurs to us, we should be aware that it is being voiced by our ego, which thinks it has found the perfect excuse to avoid performing our religious obligations. Rather, it is only by maintaining a proper balance between our communal activism and personal religious observance

that can we hope to succeed in both.<sup>78</sup>

**12 A final chance to repent:** Although God had forewarned about the impending Flood one hundred and twenty years earlier, the people did not repent during that entire span of time. Even after watching Noah enter the ark and witnessing the attendant miracles, they still didn’t repent. And yet, if they had repented at this point—even after the rain started—not only would they have been spared the Flood, they would have been showered with rains of blessing. This demonstrates the incredible power of repentance.

If repentance wielded such power in the generation of the Flood, even before the Torah (and the commandment to repent) had been given and the world was still spiritually estranged from God, how much more so is it true that nowadays, repentance has the power to transform all misfortune into good, even in a split second.<sup>79</sup>**Rain fell upon the earth:** Until the third day of creation, the world did not appear to be independent from God; it was evident that its entire existence consisted of nothing more than the Divine energy that created and sustained it. This had its parallel in the physical realm: until the third day of creation, the entire earth was covered by water. The earth’s submersion under water was a reflection of its self-nullification; its identity as a creation that appeared independent from God was concealed and nullified. This metaphor of submersion in water is also used to describe the Divine awareness that will prevail in the messianic era.<sup>80</sup>

On the third day of creation, however, God caused the dry land to emerge, which meant in spiritual terms that Divinity was obscured; the world began to appear independent from God. This condition continued until the Flood, when God caused the world to revert back to its original state of submersion under water.<sup>81</sup> During the Flood, the world’s spiritual state resembled its lofty state at the beginning of creation, when it was covered by water.

How can we possibly reconcile this lofty interpretation of the Flood with its plain significance, i.e., a means to

the Holy Temple.” 76. *Likutei Sichot*, vol. 15, pp. 42-48. 77. *Likutei Sichot*, vol. 20, pp. 289-290. 78. *Likutei Sichot*, vol. 1, pp. 5-6. 79. *Likutei Sichot*, vol. 20, p. 520. 80. Isaiah 11:9. *Mishneh Torah, Melachim* 12:5. 81. *Bereishit Rabba* 5:1.

12 Nonetheless, initially, ordinary **rain fell upon the earth**, to give the people a final chance to repent. Had they repented, the rain would have continued to fall in a normal, beneficial fashion. However, when they failed to take advantage of this opportunity to repent, it became a deluge. Although God released the entire amount of water that would descend during this flood from the heavenly storehouses of water all at once, He made it fall evenly over a period of **forty days and forty nights**.<sup>73</sup>

---

✧ CHASIDIC INSIGHTS ✧

---

Indeed, the era referred to in the *Zohar's* prophecy saw an explosion of knowledge, both in the realm of rational articulation of the inner secrets of Torah as well as in the realm of revolutionary scientific discoveries. On the one hand, we can readily understand how the revelation of the inner dimension of the Torah prepares the world for the messianic era; we are taught that these revelations are a foretaste of the Divine knowledge with which the world will be filled at that time. On the other hand, in what way do the revolutionary revelations in the realm of secular knowledge serve to prepare the world for the messianic era?

The answer is threefold:

(a) Firstly, the newly-revealed technologies provide us with a foretaste of the spiritual climate of the messianic era. At that time, our perception of Divinity will not be limited to intellectual appreciation alone. On the contrary, the *physical eye* will be able to see the Divine energy that sustains the world.<sup>74</sup> Modern technology affords us a glimpse into such empirical perception of Divinity. For example, the knowledge that a telephone or radio can enable us to hear a voice from the other side of the world gives us an *empirical* example of the concept that God sees and hears all that occurs in the universe.

Without this and similar examples, our appreciation of God's omniscience would be limited to an abstract, intellectual understanding, which does not always affect us fully. Now, however, with the aid of such examples, we can meditate upon the concept of God's omniscience based on our own empirical experience. Such meditation has a much more powerful impact, both on our emotions and on the three "garments" of thought, speech, and deed.

(b) Furthermore, new technologies can not only serve as an *example* of Divine concepts (as above); they themselves can be used to convey the new revelations of Torah's inner dimension in a way that helps prepare the world for the messianic era. In fact, this is their true and primary purpose.<sup>75</sup> When the secrets of Torah are broadcast over the radio waves, for example, they can be physically heard wherever they are broadcast throughout the entire world. This is a foretaste of the

messianic era, when Divine wisdom will spread without any restriction or limitation throughout the *entire* world and will be perceptible by our physical flesh (just as the teaching of Torah's inner dimension on the radio can be heard *physically* and instantaneously).

(c) Furthermore, scientific advances do not serve merely as a *tool* to broadcast the secrets of Torah, a means to an end; rather, they *themselves* reflect the concepts expounded in Torah's inner dimension.

This concept of God's oneness, for example is evidenced in science itself: scientists used to believe that every organism comprises many, distinct elements. But as science develops further, the more it recognizes that the diversity within the universe is only superficial and that the universe is essentially the *unification* of form and matter.

This explains the intrinsic connection between the development of the sciences and the revelation of Torah's inner dimension as a preparation for the messianic era: The revelation of Torah's inner dimension automatically leads to the development of the secular sciences. It is indeed through the latter that the foretaste of the Divine knowledge that will fill the world in the messianic era is experienced in an empirical way. When we see the world's oneness through the eyes of science, we realize that this oneness is identical to the oneness of Divinity (which is revealed through Torah's inner dimension). This, in turn, "prepares the world to be elevated in the seventh" millennium.

(The value of secular knowledge does not justify exposing ourselves to the spiritual dangers present in the vast majority of academic institutions devoted to study of secular knowledge. The atmosphere in these institutions is so saturated with atheism that it is considered an obvious truth requiring no proof. Most of these institutions also discourage modesty and chastity, tacitly if not officially, and people who do adhere to a moral code are mocked. The licentious climate on the campuses and in the dormitories is well known. All this makes college a challenging place to be a religious person. Some claim that they will not be affected by the atmosphere, but even the most righteous of people is not allowed to intentionally subject himself to

---

73. *Likutei Sichot*, vol. 25, p. 25. 74. See Isaiah 40:5. 75. See *Shemot Rabbah* 35:1: "Why was gold created? For the Tabernacle and

ONKELOS  
 13 בכרן יומא הדין על נח ושם  
 וקם ויפת בני נח ואמת נח ותלת  
 נשי בנוהי עמהון לתבותא:  
 14 אנון וכל חיותא לונה וכל  
 בעירא לונה וכל רחשא דרחש  
 על ארעא לונה וכל עופא  
 לונהי כל צפר כל דפרח:

13 בַּעֲצָם הַיּוֹם הַזֶּה בָּא נֹחַ וְשִׁם-יָוָם וַיַּפֵּת בְּנֵי-נֹחַ  
 וַאֲשֶׁת נֹחַ וּשְׁלֹשֶׁת נְשֵׁי-בָנָיו אִתָּם אֶל-הַתְּבֵה: 14 הַמָּה  
 וְכָל-הַחַיָּה לְמִינָהּ וְכָל-הַבְּהֵמָה לְמִינָהּ וְכָל-הָרֶמֶשׂ  
 הָרֶמֶשׂ עַל-הָאָרֶץ לְמִינָהּ וְכָל-הָעוֹף לְמִינָהּ כֹּל צֶפֶר  
 כָּל-כַּנָּף:

RASHI  
 כַּנָּף. דְּבוּק הוּא, צֶפֶר שֶׁל כֹּל מִין כַּנָּף, לְרַבּוֹת חַגְבִּים.  
 "כַּנָּף" לְשׁוֹן "נוֹצָה", כְּמוֹ: "וַיִּשְׁסַע אֹתוֹ בְּכַנְפָיו", שְׁאֵפֶל  
 נוֹצָתָה עוֹלָה, אֵף כָּאן: צֶפֶר כֹּל מִין מְרֵאוֹת נוֹצָה:  
 13 בַּעֲצָם הַיּוֹם הַזֶּה. לְמִדָּה הַכְּתוּב, שְׁהִיוּ בְּנֵי דוֹר  
 אוֹמְרִים: אֵלּוּ אָנוּ רוֹאִים אוֹתוֹ וְנִכְנָס לְתֵבָה, אָנוּ שׁוֹבְרִין  
 אוֹתָהּ וְהוֹרְגִין אוֹתוֹ. אָמַר הַקָּדוֹשׁ בְּרוּךְ הוּא: אָנִי  
 מְכַנְּסוֹ לְעֵינַי כְּלָם, וְנִרְאָה דְּבַר מִי יָקוּם: 14 צֶפֶר כֹּל  
 16. ויקרא א, יז.

CHASIDIC INSIGHTS

bath we become “new” people. Similarly, immersion in a *mikveh* is an integral part of the process of conversion, in which the convert becomes a “new” person.<sup>92</sup><sup>93</sup> Metaphorically, the floodwaters correspond to our financial worries, which likewise serve to purify us spiritually, as will be explained presently. In fact, the parallel between financial worries and the *mikveh* goes much deeper: The waters of the *mikveh* represent Divine awareness. When immersing ourselves in these waters, we are meant to envision ourselves submerging in Divine awareness, such that our normative awareness becomes swallowed up and submerged in Divine consciousness.<sup>94</sup> (This relationship between immersion and self-nullification is alluded to by the fact that the letters used to spell the word for “to immerse” [טבל] can be rearranged to spell the word for “to nullify” [בטל].) This is why a *mikveh* is required to contain a minimum of 40 *se’ah*: this is the amount necessary to ensure that the entire body is immersed in it at once.<sup>95</sup> In other words, immersing oneself in a *mikveh* means to transcend oneself and thereby rise to a level in which one is able to become receptive to holiness. This is also the reason why God gives us financial worries. True, they temporarily distract and confuse us, but they simultaneously also break down our walls of self-assuredness, thereby enabling us to go beyond our ego. It is then that we become receptive to holiness. Since the true purpose of financial woes is not, God forbid, to punish us but rather to deflate our inflated ego, this can be accomplished in one short moment: if we quickly extract the inner message hidden in the financial worries, thereby enabling us to transcend our

egos, we no longer need the financial worries to rectify ourselves, and can henceforth enjoy *nachat* (pleasure and calm), both physically and spiritually.<sup>96</sup> **13 God protected Noah by summoning lions:** Despite all his efforts and arduous work, ultimately Noah needed Divine intervention in order enter the ark. Similarly, if we enter the ark of Torah and prayer with only our own strength, we are not assured spiritual protection. Sometimes we can study the Torah diligently yet forget about its Author,<sup>97</sup> thus forfeiting its protective properties. Similarly, if we are immersed in our prayers without actually internalizing their message, we will fail to imbue our mundane activities with their spirit. In order for our study and prayer to be as they should, we need Divine assistance—we need God to “seal” the door of the ark behind us. And how are we deemed worthy of receiving just such assistance? By devoting ourselves to helping others. Working to save others from the “raging waters” with earnest dedication and warm devotion is the surest way to ensure that we ourselves remain unharmed.<sup>98</sup> **Noah...entered the ark:** One of the lessons we can derive from this part of the narrative is that we should never despair in the face of what is occurring in the world around us. Even when threatened with a devastating Flood, we should retain our optimism, for God watches over us and shelters us, and for Him, anything is possible. Furthermore, we should realize that by entering our spiritual “ark,” our prayers and study of the Torah can save the entire world and even raise it to a higher level of being, just as Noah “beheld a new world”<sup>99</sup> when he emerged from the ark. **24 Noah often groaned or even spit blood from sheer exhaustion. Once, he was late in delivering**

91. See *Sha'ar HaKavanot, inyan tevilat erev Shabbat, Pri Etz Chaim, Sha'ar HaShabbat*, chapter 3 ff. *Yom Tov shel Rosh HaShana* 5666, p. 387. 92. See *Yevoamot* 22a, et al: “[A convert is] like a newborn.” 93. *Reshimot*, vol. 3, p. 40. 94. See *Mishneh Torah, Mikva'ot* 11:12. 95. *Chagigah* 11a. 96. *Likutei Sichot*, vol. 1, pp. 4-5. 97. See *Nedarim* 81a. 98. *Likutei Sichot*, vol. 1, pp. 8-10. 99. *Hitva'aduyot* 5743, vol. 1, p. 400.

13 Because of the people's threats,<sup>82</sup> God protected Noah by summoning lions and bears that prevented the people from harming him or damaging the ark.<sup>83</sup> Thus **Noah entered the ark in the very midst of that day, the 17<sup>th</sup> of Marcheshvan, with Noah's sons, Shem, Ham, and Japheth, and Noah's wife, and the three wives of his sons with them.** Noah took some vine branches and fig-tree shoots along with him.<sup>84</sup>

14 **And with them, every kind of beast, every kind of livestock, every kind of creature that crawls on the ground, and every kind of flying creature—every bird and every winged creature, even locusts.**

---

∞ CHASIDIC INSIGHTS ∞

---

destroy all flesh?

The answer is that the Torah exists on two levels: (a) in its original, spiritual pre-creation state, as in the Talmudic statement, "The Torah preceded the world by two thousand years";<sup>85</sup> and (b) in its descent into this material world, where it takes on terrestrial meaning. In its primordial state, every word of the Torah has a spiritual meaning, according to which it is studied in the spiritual worlds. This refers both to the laws of the Torah as well as to its narratives: although every detail of all of the narratives in the Torah actually took place in this physical world, nevertheless, since the Torah preceded the existence of the world, it follows that the Torah's narratives also possess a spiritual meaning that is coherent in the spiritual worlds in which physicality does not exist.

In other words, it's not that the Torah can *also* be explained spiritually. On the contrary: the Torah speaks primarily about the supernal and alludes only secondarily to the terrestrial.<sup>86</sup> The Torah exists originally in a heavenly, spiritual state and from there descends into this world and "dons" terrestrial garb.

In addition, nothing in the primordial Torah is evil, since there is no evil in the supernal worlds. Everything that appears negative in the Torah's terrestrial meaning is, in fact, good and holy in its primordial origin. In a similar vein regarding the Flood: the statement that the Flood came to punish the people and even to purify the world only holds true in the Torah's *terrestrial* context. In its supernal context, where evil and impurity do not exist, it cannot be claimed that the purpose of the Flood was to destroy evildoers or to cleanse the world from its impurity; it can only be the expression of an increase in holiness. Indeed, in Jewish law, immersion in a *mikveh* not only purifies the impure, but also elevates someone who is already pure to a higher level of purity. For example, on Yom Kippur, the High Priest would immerse himself five times, even though he was already technically pure after the first immersion. The subsequent immersions were intended to elevate him

to progressively higher levels within the realm of holiness.

Moreover, the supernal version of events affects the terrestrial version as well. Thus, the physical waters of the Flood, which wiped out all flesh and cleansed the world of impurity, also increased the world's holiness, similar to how the waters function in the primordial Torah.

By way of metaphor: The love of parents for their children as it exists in its truest and strongest form within their hearts is pure goodness. But when children misbehave, the parents express their love by punishing them, for their own benefit, to train them to refrain from self-destructive behavior.<sup>87</sup> Similarly, the waters of the Flood as they exist in the supernal Torah, in the "heart of the Parent," are love and goodness. As the floodwaters descend into this world, they become waters of punishment and purification. But even then, they never lose their essential nature, which is love and goodness.<sup>88</sup>

**Forty days and forty nights:** As mentioned, the Flood served not only as a punishment but also as a spiritual cleansing for a world that had become spiritually contaminated. This is why the waters of the Flood are called "the waters of Noah,"<sup>89</sup> meaning "the waters of [Divine] pleasure and satisfaction [*nachat*]."

Inasmuch as spiritual defilement is associated with the concept of death, spiritual purification is a form of rebirth. This is why the flooding lasted for forty days and nights, since the number forty is related to purification and rebirth: it takes forty days from the time of conception for a fetus to become completely formed. Similarly, the minimum amount of water that must be present in a *mikveh* (a ritual pool used for spiritual cleansing), through which a person becomes spiritually "reborn," is 40 *se'ah*.<sup>90</sup> (Indeed, precisely due to the fact that immersion in a *mikveh* is an experience of rebirth, many Jews have the custom to immerse themselves in a *mikveh* before the Sabbath,<sup>91</sup> since on the Sab-

---

82. See 6:22, above. 83. Rashi on v. 16, below. 84. Rashi on 9:20, below. 85. *Shabbat* 88b, et al. 86. *Asarah Ma'amarot, Ma'amar Chikur Din* 3:22. See Proverbs 8:30. 87. See Proverbs 13:24. 88. *Likutei Sichot*, vol. 30, pp. 16-21. 89. Isaiah 54:9. 90. A *se'ah* is a biblical measure equaling approximately 2.18 gallons. A *mikveh* would thus require a minimum of 87.2 gallons.

— ONKELOS —

15 ועלו לות נח לתבותא תרין  
תרין מכל בשרא די בה רוחא  
דחיי: 16 ועלא דכר ונוקבא מכל  
בשרא עלו במה דפקד יתה יי  
ואגו יי במימרה עלוהי: 17 והנה  
טופנא ארבעין יומין על ארעא  
וסגיאו מיא ונטלו ית תבותא  
ואתרמת מעל ארעא: 18 ותקיפו  
מיא וסגיאו לחדא על ארעא  
ומהלכא תבותא על אפי מיא:  
19 ומיא תקיפו לחדא לחדא על  
ארעא ואתחפיו כל טוריא רמיא  
די תחות כל שמיא: 20 חמש  
עשרי אמין מלעלא תקיפו מיא  
ואתחפיו טוריא: 21 ומית כל  
בשרא דרחש על ארעא בעופא  
ובבעררא ובחיותא ובכל רחשא  
דרחש על ארעא וכל אנשא:

15 ויבאו אל־נח אל־התבה שנים שנים מכל־הבשר  
אשר־בו רוח תיים: 16 ותבאים זכר ונקבה מכל־בשר  
באו באשר צוה אתו אלהים ויסגר יהוה בעדו:  
שלישי 17 והי המבול ארבעים יום על־הארץ וירבו  
המים וישאו את־התבה ותָרם מעל הארץ: 18 ויגברו  
המים וירבו מאד על־הארץ ותלך התבה על־פני המים:  
19 והמים גברו מאד מאד על־הארץ וכסו כל־ההרים  
הגבהים אשר־תחת כל־השמים: 20 חמש עשרה אמה  
מלמעלה גברו המים וכסו ההרים: 21 ויגוע כל־בשר |  
הרמש על־הארץ בעוף ובבהמה ובחיה ובכל־השרץ  
השרץ על־הארץ וכל האדם:

— RASHI —

עבדיך: 17 ותָרם מעל הארץ. משקעת היתה במים  
אחת עשרה אמה, בספינה טעונה המשקעת מקצתה  
במים. ומקראות שלפנינו יוכיחו: 18 ויגברו. מאליהן:  
20 חמש עשרה אמה מלמעלה. למעלה של גובה כל  
ההרים, לאחר שהשוו המים לראשי ההרים:

16 ויסגר ה' בעדו. הגן עליו שלא שברוה, הקיף התבה  
דבים ואריות והיו הורגים בהם. ופשוטו של מקרא: סגר  
כנגדו מן המים, וכן כל "בעד" שבמקרא לשון "כנגד"  
הוא: "בעד כל רחם"<sup>17</sup>, "בעדך ובעד בניך"<sup>18</sup>, "עור בעד  
עור"<sup>19</sup>, "מגן בעדי"<sup>20</sup>, "התפלל בעד עבדיך"<sup>21</sup> — כנגד

17. בראשית כ, יח. 18. מלכים ב, ד, ד. 19. איוב ב, ד. 20. תהלים ג, ד. 21. שמואל א, יב, יט.

**20 The mountains were covered, and the waters surged fifteen cubits above Mount Ararat, the highest of them in the region.**

**21 All flesh that moved upon the earth perished: including the birds, the livestock, the beasts, and every crawling creature that swarmed on the earth, as well as all humanity.**

INNER DIMENSIONS

[20] **The waters surged fifteen cubits above:** As we have seen, entering the ark is a metaphor for immersing oneself in the words of prayer; hence the connection between the ark and the number fifteen, since many aspects of our prayers relate to the number fifteen. A few examples:

- There are fifteen expressions of praise in the prayer *Yishtabach* (song, praise, etc.).
- Most of the prayers in the section of the liturgy called "Verses of Praise" [*Pesukei d'Zimrah*] begin and end with the word *Hallelujah*, the last letters of which (*yud* and *hei*) equal fifteen.
- In the prayer *Emet v'Yatziv*, there are fifteen successive words that begin with the letter *vav*.

King David recited fifteen songs of ascent (Psalms 120-134) in order to protect the world from the waters of the deep.<sup>109</sup>

Additionally, fifteen is the numerical value of the first half of the Name *Havayah*, the letters *yud* and *hei*. The Torah's passive commandments (the prohibitions) are associated with these two letters. In contrast, the active commandments are associated with the second half of the Name *Havayah*, the letters *vav* and *hei*. Since the people had sinned by transgressing the prohibitions of the Torah—licentiousness, theft, etc.—which are associated with the first half of the Name *Havayah*, the waters surged to a height of fifteen cubits.<sup>110</sup>

109. *Sukah* 53a; *Or HaTorah Bereishit*, vol. 3, p. 1252. 110. *Or HaTorah, Bereishit*, vol. 3, p. 1252.

15 Of all flesh that had in it a breath of life, they came to Noah into the ark, in pairs.

16 Those who came were male and female; of all flesh they came, as God had commanded him, and God sealed the entrance behind him.

The animals that came to the ark behaved peacefully, even on their way to the ark. Even the wild beasts harmed neither the other animals nor Noah during their stay in the ark.<sup>100</sup>

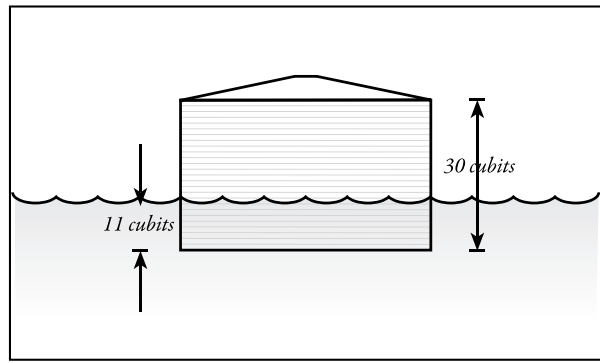

Figure 7: The Ark in the Water

◆ **Third Reading** 17 The Flood was upon the earth for forty full days, until the night of the 28<sup>th</sup> of Kislev. The waters increased and lifted the ark, and it rose above the ground.

18 The waters surged and increased greatly over the earth, and the ark drifted on the surface of the water, eleven cubits of its height remaining submerged under the surface of the water.

19 The waters surged exceedingly high over the earth, and all the high mountains under the whole sky were covered.

#### ☞ A CLOSER LOOK ☞

[16] The animals that came to the ark behaved peacefully: There are a number of parallels between Noah's ark and the sukah that we are commanded to build and live in during the holiday of Sukot:

(a) In the ark, all the animals coexisted in peace and unity. Similarly, the sukah is an expression of Jewish unity, inasmuch as we are permitted to use another Jew's sukah to fulfill our own obligation to live in a sukah during the holiday. (In contrast, it is not permissible to fulfill our obligation to hold a set of the four plants of Sukot with a borrowed set.)<sup>101</sup> In the liturgy,<sup>102</sup> the sages even use the sukah as a metaphor for peace: "Spread over us the sukah of Your peace."

(b) The actual construction of the ark was an integral part of God's command to Noah to go into the ark. Similarly, the actual construction of a sukah is an integral part of fulfilling the commandment to live in a sukah. (Therefore, according to some opinions, a blessing must be recited upon building a sukah.<sup>103</sup>)

(c) The materials used to construct the ark had to be Noah's property.<sup>104</sup> Similarly, a sukah must be made

out of the owner's own materials (or materials he has been given permission to use) and is not valid if made out of stolen materials.<sup>105</sup>

(d) The purpose of the ark was to provide protection and shelter; similarly, the sukah serves as a reminder of how the Clouds of Glory sheltered and protected us in the desert.<sup>106</sup>

Yet we also find distinctions between the ark and the sukah:

(a) Whereas Noah had to build the ark himself, we are permitted to delegate the building of a sukah to another Jew.

(b) Whereas the ark had to be Noah's own property, we may use someone else's sukah if the owner grants permission us to do so.

The reason for these differences is that, as mentioned above,<sup>107</sup> Noah was not overly concerned with the fate of his fellow human beings. His ark was therefore a private affair and he was not allowed to involve anyone else in it. The Torah, however, transformed all Jews into one entity, and therefore a borrowed sukah or one built for us by another can be considered our own.<sup>108</sup>

100. *Likutei Sichot*, vol. 25, p. 29. 101. *Sukah* 27b. 102. Night prayer (*Arvit*), second blessing after reciting the *Shema*. 103. *Y. Berachot* 9:3. Practically, we follow the opposing opinion, that a blessing is not recited, not because the construction in itself is not a *mitzvah*, but because it is not the *culmination* of the *mitzvah*. 104. *Tzafnat Paneiach* on this verse. 105. *Shulchan Aruch, Orach Chayim* 637. 106. *Exodus* 13:21; *Leviticus* 23:43; *Shulchan Aruch, Orach Chayim* 635. 107. On 6:14. 108. *Likutei Sichot*, vol. 15, pp. 39-41.

## ONKELOS

22 כל די נשמת רוח חיינ בַּאֲפוּי אֲשֶׁר  
מכל די בַּיְבֻשְׁתָּא מיתו: 23 ומקא  
ית כל יקומא די על אפי ארעא  
מאגשא עד בעירא עד רחשא  
ועד עופא דשמאי ואתמחיא  
מן ארעא ואשתאר בַּרְס נח ודי  
עמה בַּתְּבוּתָא: 24 ותקיפו מיא  
על ארעא מאה וחמשין יומין:  
8:1 ודכיר יי ית נח וית כל חיותא  
וית כל בעירא די עמה בַּתְּבוּתָא  
ואעבר יי רוחא על ארעא ונחו  
מיא: 2 ואסתכרו מבועי תהומא  
וכוי שמאי ואתכלי מטרא מן  
שמאי: 3 ותבו מיא מעל ארעא  
אולין ותביין וחסרו מיא מסוף  
מאה וחמשין יומין:

22 כָּל אֲשֶׁר נִשְׁמַת־רוּחַ חַיִּים בְּאֲפוּי מִכָּל אֲשֶׁר  
בַּחֲרָבָה מֵתוּ: 23 וַיִּמַח אֶת־כָּל־הַיְקוּם | אֲשֶׁר | עַל־פְּנֵי  
הָאֲדָמָה מֵאָדָם עַד־בְּהֵמָה עַד־רֶמֶשׂ עַד־עוֹף הַשָּׁמַיִם  
וַיִּמָּחוּ מִן־הָאָרֶץ וַיִּשְׁאָר אֲדֹנָיִךְ וְאַשֶׁר אִתּוֹ בַּתְּבֵה:  
24 וַיִּגְבְּרוּ הַמַּיִם עַל־הָאָרֶץ חֲמֵשִׁים וּמֵאֵת יוֹם: 8:1 וַיִּזְכֹּר  
אֱלֹהִים אֶת־נֹחַ וְאֵת כָּל־הַחַיָּה וְאֵת־כָּל־הַבְּהֵמָה אֲשֶׁר  
אִתּוֹ בַּתְּבֵה וַיַּעֲבֵר אֱלֹהִים רוּחַ עַל־הָאָרֶץ וַיִּשְׁכּוּ הַמַּיִם:  
2 וַיִּסְכְּרוּ מַעֲיֵנֵת תְּהוֹם וְאֶרֶבֶת הַשָּׁמַיִם וַיִּכְלֵא הַגִּשְׁמִים  
מִן־הַשָּׁמַיִם: 3 וַיִּשְׁכּוּ הַמַּיִם מֵעַל הָאָרֶץ הַלֹּוֹךְ וַיִּשׁוּב  
וַיַּחֲסְרוּ הַמַּיִם מִקְצֵה חֲמֵשִׁים וּמֵאֵת יוֹם:

## RASHI

זכר להם לבהמות וכותי? שלא השחיתו דרךם קדם לכן,  
ושלא שמשו בתבה: ויעבר אלהים רוח. רוח תנחומין  
והנחה עברה לפניו: על הארץ. על עסקי הארץ: וישבו.  
כמו<sup>25</sup>: "כשך חמת המלך", לשון הנחת חמה: 2 ויסכרו  
מעינת. כשנפתחו<sup>26</sup> כתיב: "כל מעינות", וכאן אין כתיב  
"כל", לפי שגשגו מיהם אותן שיש בהם צורך לעולם,  
כגון חמי טבריא וכיוצא בהן: ויכלא. וימנע, כמו: "לא  
תכלא רחמיך"<sup>27</sup>, "לא יכלה ממך"<sup>28</sup>: 3 מקצה חמשים  
ומאת יום. התחילו לחסור, והוא אחד בסיון. כיצד?  
כ"ז בכסלו פסקו הגשמים, הרי שלשה מכסלו ועשרים  
ותשעה מטבת הרי שלשים ושתיים, ושבת ואדר וניסן  
ואיר — מאה ושמונה עשר, הרי מאה וחמשים:

22 נשמת רוח חיים. נשימה של רוח חיים: אש  
בחרבה. ולא דגים שבים: 23 וימח. לשון "ויפעל"  
הוא, ואינו לשון "ויפעל", והוא מגזרת "ויפן" ו"יבן". כל  
תבה שסופה ה"א, כגון: "בנה" "מחה" "קנה", כשהוא  
נומן ו"י"ו בראשה נקוד בחירק תחת ה"ו"ד: אף נח.  
לבד נח, והו פשוטו. ומדרש אגדה<sup>29</sup>: גזנח וכוהה דם,  
מטורח הבהמות והחיות. ויש אומרים, שאחר מזונות  
לארי והכישו, ועליו נאמר<sup>30</sup>: "הן צדיק בארץ ישלם":  
1 ויזכר אלהים. זה השם מדת הדין הוא, ונהפכה  
למדת רחמים על ידי תפלת הצדיקים. ורשעתן של  
רשעים הופכת מדת רחמים למדת הדין, שנאמר<sup>31</sup>:  
"וירא ה' כי רבה רעת האדם וגו' ויאמר ה' אמחה",  
והוא שם מדת רחמים: ויזכר אלהים את נח וגו'. מה

22. תנחומא נח, ט. 23. משלי יא, לא. 24. בראשית ו, ה"ז. 25. אסתר ב, א. 26. לעיל ז, יא. 27. תהלים מ, יב. 28. בראשית כג, ו.

## CHASIDIC INSIGHTS

**the lion's meal, and it struck him:** Metaphorically, Noah's feeding the animals can be likened to our providing spiritual nourishment to others. When, at times, we encounter major difficulties in this work, we must persevere under all circumstances, as Noah did, especially since the hardships and discomforts that we encounter are rarely so severe as to cause us to "groan and spit blood."

Nevertheless, even as we learn to overlook our own personal discomforts, we must learn to be acutely

sensitive to our fellows' discomfort (and not analyze whether what others require is a necessity or a luxury<sup>116</sup>), and provide for their needs on time, for two reasons: Firstly, we have no way of estimating other people's worth or true stature; each one might possess a lofty soul, a "lion," a "king."<sup>117</sup> And secondly, while it is proper to assume that we ourselves deserve all the hardships that may befall us in life, we must assume that others deserve only the best.<sup>118</sup>

116. Ketubot 67b. 117. See Pesachim 50a. 118. Likutei Sichot, vol. 5, pp. 53-56.

**22 Every being that had the breath of the spirit of life in its nostrils, every being that was on dry land, died.** The fish, however, remained alive.

**23 God obliterated every being that had been on the face of the earth—from man, to livestock, to reptiles, to the birds of the heavens. They were obliterated from the earth; Noah and those who were with him in the ark survived** and were greatly pained by their isolation. The descendants of the giants Shamchazai and Azael,<sup>111</sup> however, survived the floodwaters,<sup>112</sup> and eventually settled around Hebron.<sup>113</sup>

The floodwaters swept all the corpses of those who perished to the lowlands of Babylonia.<sup>114</sup>

**24 The waters surged over the earth for an additional 150 days** after the rainfall stopped, and did not subside throughout this entire period—from the 28<sup>th</sup> of Kislev until the 29<sup>th</sup> of Iyar.

The task of caring for the animals was extremely strenuous, and Noah often groaned or even spit blood from sheer exhaustion. Once, he was late in delivering the lions' meal, and one of them struck him. (This incident was the only exception to the animals' otherwise peaceful behavior in the ark. God made this happen once in order to show Noah that He holds righteous people such as Noah to a very high standard of behavior and that He punishes their slightest misdeeds in this world in order for them to have a clean slate in the afterlife.<sup>115</sup>) Noah and his family therefore prayed to God to relieve their suffering in the ark.

**8:1** On account of Noah's prayers, **God** ceased treating the world, as He had done until then, with His attribute of strict justice, and instead began allowing His attribute of mercy to dominate. He thus **remembered Noah**. He also remembered that **all the beasts and livestock with him in the ark** had not engaged in crossbreeding, neither before entering the ark nor during their stay within it. **God caused His spirit** of consolation and rest **to apply to** what was happening on **earth, and the waters began to subside**.

**2** When it stopped raining on the 28<sup>th</sup> of Kislev, most of **the wellsprings of the abyss were sealed**, but some of them were left open to serve as hot springs. In contrast, **all the floodgates of heaven were sealed**. Thus **the rain from the heavens was held back**.

**3** **At the end of 150 days** from the 28<sup>th</sup> of Kislev, i.e., beginning on the 1<sup>st</sup> of Sivan, **the waters slowly but steadily receded from upon the earth and the waters diminished**. The water level dropped one-fourth of a cubit per day, **so that**

<sup>111</sup>. See above, 6:2. <sup>112</sup>. *Likutei Sichot*, vol. 28, p. 89. <sup>113</sup>. Numbers 13:33. <sup>114</sup>. Rashi on 6:17, above. <sup>115</sup>. *Likutei Sichot*, vol. 5, pp. 52-53.

— ONKELOS —  
 4 וְנָחַת תְּבוּחַת אֶת־בְּרִיחַא שְׂבִיעָאָה בְּשִׁבְעַת עֶשְׂרָא יוֹמָא לְיִרְחָא עַל טוּרֵי קְרָדוּ: 5 וּמִיָּא הוּוּ אֶזְלִין וְחֶסְרִין עַד יִרְחָא אֶשְׂרִיָּאָה בְּעֶשְׂרִיָּאָה בְּחַד לְיִרְחָא אֶתְחַזִּיאֻ רִישֵׁי טוּרֵיָא: 6 וְהָהּ מִסּוּף אֶרְבָּעִין יוֹמִין וּפְתַח נֹחַ יָת כּוֹת תְּבוּחַת דִּי עֶבֶד: 7 וְשִׁלַּח יָת עוֹרְבָא וּנְפַק מִפֶּק וְתָאב עַד דִּיבִישׁוּ מִיָּא מַעַל אֶרְעָא:

4 וַתִּנַּח הַתֵּבָה בַּחֹדֶשׁ הַשְּׁבִיעִי בְּשִׁבְעַת־עֶשְׂרֵי יוֹם לַחֹדֶשׁ  
 עַל הַרֵי אֲרָרָט: 5 וְהַמַּיִם הָיוּ הֶלֶדֶד וְחִסּוֹר עַד הַחֹדֶשׁ  
 הָעֲשִׂירִי בְּעֶשְׂרִי בְּאַחַד לַחֹדֶשׁ נִרְאוּ רֵאשֵׁי הַהָרִים:  
 6 וַיְהִי מִקֵּץ אַרְבָּעִים יוֹם וַיִּפְתַּח נֹחַ אֶת־חַלּוֹן הַתֵּבָה  
 אֲשֶׁר עָשָׂה: 7 וַיִּשְׁלַח אֶת־הָעוֹרֵב וַיֵּצֵא יֵצוּא וְשׁוֹב עַד־  
 יִבְשֶׁת הַמַּיִם מֵעַל הָאָרֶץ:

— RASHI —

זה סיון. והעשירי אי אפשר למנות אלא לירידה, שאם אתה אומר להפסקה והוא אלול, אי אתה מוצא "בראשון באחד לחדש חרבו המים מעל הארץ", שהרי מקץ ארבעים יום משגראו ראשי ההרים שלח את העורב, ועשרים ואחד יום הוחיל בשליחות היונה, הרי ששים יום משגראו ראשי ההרים עד שחרבו פני האדמה. ואם תאמר: באלול נראו, נמצא שחרבו במרחשון, והוא קורא אותו ראשון, ואין זה אלא תשרי שהוא ראשון לבריאת עולם, ולרבי יהושע הוא ניסן: 6 **מקץ ארבעים יום.** משגראו ראשי ההרים: **את חלון התבה אשר עשה.** לצהר. ולא זה פתח התבה העשוי לביאה ויציאה: 7 **יצוא ושוב.** הולך ומקיף סביבות התבה. ולא הלך בשליחותו, שהיה חושרו על בת זוגו, וכמו ששינינו באגדת "חלק"<sup>123</sup>: **עד יבשת המים.** פשוטו כמשמעו. אבל מדרש אגדה<sup>124</sup>: מוכן היה העורב לשליחות אחרת, בעצירת גשמים בימי אליהו, שנאמר<sup>125</sup>: "והעורבים מבאים לו לחם ובשר":

4 **בחודש השביעי.** סיון, והוא שביעי לכסלו, שבו פסקו הגשמים: **בשבעה עשר יום.** מכאן אתה למד שהיתה התבה משקעת במים אחת עשרה אמה. שהרי כתיב<sup>29</sup>: "בעשירי באחד לחדש נראו ראשי ההרים", זה אב שהוא עשירי למרחשון לירידת גשמים, והם היו גבוהים על ההרים חמש עשרה אמה, וחסרו מיום אחד בסיון עד אחד באב חמש עשרה אמה לששים יום, הרי אמה לארבעה ימים. נמצא שבי"ו בסיון לא חסרו המים אלא ארבע אמות, ונקה התבה ליום המחרת. למדת, שהיתה משקעת אחת עשרה אמה במים שעל ראשי ההרים: 5 **בעשירי וגו' נראו ראשי ההרים.** זה אב, שהוא עשירי למרחשון שהתחיל הגשם. ואם תאמר: הוא אלול, ועשירי לכסלו שפסק הגשם, כשם שאתה אומר בחודש השביעי – סיון, והוא שביעי להפסקה? אי אפשר לומר כן, על כרחך שביעי אי אתה מונה אלא להפסקה, שהרי לא כלו ארבעים יום של ירידת גשמים ומאה וחמשים של תגברת המים עד אחד בסיון, ואם אתה אומר שביעי לירידה, אין

129. פסוק ה. 30. סנהדרין קח, ב. 31. בראשית רבה לז, ה. 32. מלכיס"א יז, ו.

INNER DIMENSIONS

[4] **On the seventeenth of...the seventh month the ark came to rest:** According to the *Zohar*, the seventh month refers to the month of Tishrei, which is the seventh month from Nisan. During this seventh month, on Rosh HaShanah, God sits, so to speak, upon "the Throne of Judgment." This is alluded to in the phrase:

*The ark came to rest on the mountains of Ararat:* The "Mountains of Ararat" allude to the prosecuting angels who demand that justice be done and punishment meted out. But through our prayers and shofar-blowing on Rosh HaShanah, we transform judgment into mercy.<sup>123</sup>

The parallel between the ark and Rosh HaShanah can also be seen in the following: Rosh HaShanah is the day on which our Matriarchs, Sarah and Rachel,

as well as Chanah (the mother of the prophet Samuel), who were all barren, were remembered on High and subsequently conceived.<sup>124</sup> Each of these three-letter names contains one unique letter that appears only in that particular name, whereas the remaining two letters also appear in the other names, as well.

*Sarah:* the unique letter in the name Sarah is *sin*, whose numerical value is 300, corresponding to the 300-cubit length of the ark;

*Rachel:* the unique letter in the name Rachel is *lamed*, whose numerical value is 30, corresponding to the 30-cubit height of the ark;

*Chanah:* the unique letter in the name Chanah is *nun*, whose numerical value is 50, corresponding to the 50-cubit width of the ark.<sup>125</sup>

123. *Zohar* 3:149b. 124. *Rosh Hashanah* 10b. 125. *Likutei Levi Yitzchak, Igrot*, p. 382.

4 after sixteen days, that is, **on the seventeenth day of the month** of Sivan, which was **the seventh month** counting from when the rain stopped falling, in Kislev, **the ark came to rest on the Mountains of Ararat** (see figure 8). Since the water reached to a height of fifteen cubits above the mountaintop<sup>119</sup> and the bottom of the ark was submerged eleven cubits below water level,<sup>120</sup> the water level only had to drop four cubits to allow the ark to rest on the peak of Mount Ararat.

5 **The waters continued to diminish** at this rate for another forty-four days, i.e., **until** the first day of Menachem Av, **the tenth month** counting from when the rain stopped falling, in Kislev.

In the course of these forty-four days, the water level dropped an additional eleven cubits. Thus, **in the tenth month, on the first of the month**, the height of the water had receded a total of fifteen cubits, and **the highest mountain peaks became visible**.

6 Once the ark firmly settled on the mountaintop, the water began to recede much faster. **Forty days after** the highest mountaintops became visible, i.e., on the 10<sup>th</sup> of Elul, **Noah opened the window he had made in the ark**.

7 On the next day, the 11<sup>th</sup> of Elul, **he sent out the raven** to see if the water had receded completely. He assumed that the raven would not return if it would find a place to rest. But because the raven was afraid that Noah would harm its mate, when **it went out**, it circled **to and fro** around the ark **until the water dried up from the surface of the earth**. (Because the raven did not fulfill its mission, God miraculously prolonged its life and sent it to fulfill a similar mission during the lifetime of the prophet Elijah.<sup>121</sup>)



Figure 8: Mt. Ararat

∞ CHASIDIC INSIGHTS ∞

6-7 **To see if the water had abated:** It would seem that since Noah had entered the ark by God's explicit instruction, he would also have to await a similar instruction to exit it. Indeed, it was not until after God instructed him to leave the ark that he did so.<sup>122</sup> Why, then, did he bother investigating the water level to see if the time was ripe to leave the ark?

The answer is as follows: Since God had entrusted him with the formidable task of caring for the survival of the world—by building the ark, taking in the animals, and feeding them so that they could survive and then repopulate the world after the Flood—he felt that he had to take the natural steps that would facilitate the earth's rehabilitation, i.e., to create a natural "ves-

sel" for God's blessing. So, as soon as he thought that the waters had sufficiently subsided to allow him to emerge from the ark, set foot on dry land, and begin the process of repopulating the world, he didn't hesitate nor tarry; he immediately took the steps which would help him to determine the earth's condition, i.e., sending out the raven and, a few days later, sending out the dove.

Furthermore, Noah's efforts—which revealed his great yearning to leave the ark and fulfill the task that God had given him—in fact expedited God's command to leave the ark.

This lesson is particularly relevant and timely, as we approach the messianic era and the end of the exile.

119. Above, 7:20. 120. Above, 7:18. 121. See 1 Kings 17:6. 122. Below, v. 16.

ONKELOS

8 וְשַׁלַּח יְת יוֹנָה מִלִּוְתָה לְמַחֲוֵי  
 אִם קָלוּ מֵיָא מַעַל אֲפִי אֲרַעָא:  
 9 וְלֹא אֲשַׁבַּחַת יוֹנָה מִנַּח לְפָרְסַת  
 רְגֵלָה וְתַבַּת לִוְתָה לְתַבּוּתָא אָרִי  
 מֵיָא עַל אֲפִי כָל אֲרַעָא וְאוֹשִׁיט  
 יְדָה וְנִסְבָּה וְאָעַל יְתָה לִוְתָה  
 לְתַבּוּתָא: 10 וְאוֹרִיף עוֹד שְׁבַעָא  
 יוֹמִין אֲחַרְנִין וְאוֹסִיף שְׁלַח יְת  
 יוֹנָה מִן תַּבּוּתָא: 11 וְאָתַת לִוְתָה  
 יוֹנָה לְעַדן רַמְשָׁא וְהָא טָרַף וְיָתָא  
 תְּבִיר מַחַת בְּפִמָּה וְיַדַּע נַח אָרִי  
 קָלוּ מֵיָא מַעַל אֲרַעָא: 12 וְאוֹרִיף  
 עוֹד שְׁבַעָא יוֹמִין אֲחַרְנִין וְשַׁלַּח  
 יְת יוֹנָה וְלֹא אוֹסִיפַת לְמַתְב לִוְתָה  
 עוֹד: 13 וְהָהּ בְּשִׁית מָאָה וְיָדָא  
 שְׁנִין בְּקַדְמָאָה בְּחַד לְיָרְחָא נְגוּבו  
 מֵיָא מַעַל אֲרַעָא וְאֲעֵדִי נַח יְת  
 חוּפָאָה דְתַבּוּתָא וְחוּזָא וְהָא נְגוּבו  
 אֲפִי אֲרַעָא: 14 וּבִיָרְחָא תַּנְיָנָא  
 בְּעֶשְׂרִין וְשְׁבַעָא יוֹמָא לְיָרְחָא  
 בִּישַׁת אֲרַעָא:

8 וַיִּשְׁלַח אֶת־הַיּוֹנָה מֵאֲתָו לְרֹאוֹת הַקָּלוּ הַפְּיִים מֵעַל פְּנֵי  
 הָאָרֶץ: 9 וְלֹא־מָצָאָהּ הַיּוֹנָה מְנוּחַ לְכַף־רַגְלָהּ וַתֵּשֶׁב  
 אֵלָיו אֶל־הַתֵּבָה בֵּי־מַיִם עַל־פְּנֵי כָל־הָאָרֶץ וַיִּשְׁלַח יְדוֹ  
 וַיִּקְחָהּ וַיָּבֵא אֹתָהּ אֵלָיו אֶל־הַתֵּבָה: 10 וַיַּחַל עוֹד שִׁבְעַת  
 יָמִים אַחֲרָיִם וַיִּסָּף שַׁלַּח אֶת־הַיּוֹנָה מִן־הַתֵּבָה: 11 וַתָּבֵא  
 אֵלָיו הַיּוֹנָה לֵּעֵת עֶרֶב וְהִנֵּה עֹלֶה־זֵית טָרַף בְּפִיהָ וַיַּדַּע  
 נַח בֵּי־קָלוּ הַפְּיִים מֵעַל הָאָרֶץ: 12 וַיַּחַל עוֹד שִׁבְעַת  
 יָמִים אַחֲרָיִם וַיִּשְׁלַח אֶת־הַיּוֹנָה וְלֹא־יָסָפָה שׁוֹב־אֵלָיו  
 עוֹד: 13 וַיְהִי בֹאֶחַת וְשֵׁשׁ־מֵאוֹת שָׁנָה בְּרֵאשׁוֹן בְּאַחַד  
 לַחֹדֶשׁ חָרְבוּ הַמַּיִם מֵעַל הָאָרֶץ וַיִּסַּר נַח אֶת־מִכְסֵה  
 הַתֵּבָה וַיֵּרָא וְהִנֵּה חָרְבוּ פְּנֵי הָאָרֶץ: 14 וּבַחֹדֶשׁ הַשְּׁנִי  
 בְּשִׁבְעָה וָעֶשְׂרִים יוֹם לַחֹדֶשׁ יָבִישָׁה הָאָרֶץ: 8

RASHI

מזון, ודרך־שׁו: "בפיה" לשון מאמר, אמרה: יהיו מזונותי  
 מרורין כזית בידו של הקדוש ברוך הוא, ולא מתקוין  
 כדבש בידי בשר ודם: 12 וַיַּחַל. הוא לשון "ויחל",  
 אלא שנה לשון "ויפעל" וזה לשון "ויתפעל", "ויחל"  
 — וימתן, "וייחל" — ויתמתן: 13 בְּרֵאשׁוֹן. לרבי  
 אליעזר הוא תשרי, ולרבי יהושע הוא ניסן: חָרְבוּ.  
 נעשה כמין טיט, שקרמו פניה של מעלה: 14 בְּשִׁבְעָה  
 וָעֶשְׂרִים. וירידתן בחודש השני ב"ז. אלו אחד עשר  
 ימים שהחמה יתרה על הלכנה, שמשפט דור המבול  
 שנה תמימה היה: יָבִישָׁה. נעשה גריד פה־לכְתָּה:

8 וַיִּשְׁלַח אֶת הַיּוֹנָה. לטוף שבע ימים, שהרי כתיב:  
 "ויחל עוד שבעת ימים אחרים", מכלל זה אתה למד  
 שאף בראשונה הוחיל שבעה ימים: וַיִּשְׁלַח. אין זה  
 לשון שליחות, אלא לשון שלוח, שלחה ללכת לדרך,ה.  
 וקזו יראה אם קלו הפנים, שאם תמצא מנוח לא תשוב  
 אליו: 10 וַיַּחַל. לשון המתנה, וכו':<sup>33</sup> "לי שמעו ויחלו",  
 והרבה יש במקרא: 11 טָרַף בְּפִיהּ. אומר אני שוכר  
 היה, לכן קוראו פעמים לשון זכר ופעמים לשון נקבה,  
 לפי שקל יונה שבמקרא לשון נקבה, כמו: "כיונים על  
 אפיקי מים רחצות"<sup>35</sup>, "כיוני הגאיות כלם דומות"<sup>36</sup>,  
 "כיונה פותה"<sup>37</sup>: טָרַף. חטף. ומדרש אגדה<sup>38</sup> לשון

33. פסוק י. 34. איוב כט, כא. 35. שיר 36. יחזקאל ז, טו. 37. חושע ז, יא. 38. עירובין יח, ב.

CHASIDIC INSIGHTS

cries of "We want Mashiach now!" and "How much longer?" He will surely hasten the command of "Leave the ark," instructing us to leave the exile and enter a new world.<sup>134</sup>  
 14 **Exactly one solar year:** Rashi refers to it not as a "solar" year but as a "complete" year. This idiom emphasizes that, spiritually, the year in which the Flood took place was not just a solar year, but rather the synthesis of a lunar year, which is 354 days, and a solar year—a complete year.  
 The explanation for this is rooted in the differences between studying the Torah and performing the commandments, on the one hand, and engaging in mun-

dane activities, on the other. The Torah and the commandments are like the sun since, like the sun, they are self-illuminating. Mundane activities, in contrast, are like the moon: lightless by nature until we illuminate them with properly-focused intentions.  
 Now, one would assume that since the Flood is a metaphor for engagement with the mundane, it should have lasted one lunar year. Why, then, did it last an extra eleven days to constitute a complete year?  
 The answer is that the *synthesis* of the two modes of action creates an additional element of completeness. For example, if we discuss the Torah while eating with others, we are considered to have "eaten at God's table."<sup>135</sup>

134. Hitva'aduyot 5745, vol. 4, pp. 2407-2409.

8 Seven days later, on the 18<sup>th</sup> of Elul, Noah sent out the dove to see if the water had subsided from the surface of the earth. Here again, he knew that the dove, like the raven before it, would not return if it would find a place to land.

9 But the dove could not find any place to rest its feet, and it returned to him, to the ark, for there was still water over the entire surface of the earth. He stretched out his hand and took it, and brought it to himself into the ark.

10 He waited another seven days, until the 25<sup>th</sup> of Elul, and once again sent the dove out from the ark.

11 The dove came back to him toward evening, and behold, it had plucked an olive leaf with its beak. Olive trees are particularly hardy, so it makes sense that some had survived the flood. On the other hand, the flood had surely destroyed any foliage that might have been on these trees. The leaf that the dove had brought back looked fresh (and not like an old leaf that had been floating on the water for a year), and the appearance of the stem showed clearly that the dove had *plucked* it off the tree. These clues indicated that the water had subsided long enough ago to allow sufficient time for such a leaf to grow. Thus, even if the dove *had* plucked the leaf off a tree on a mountaintop, it would still mean that enough time had elapsed for the rest of the earth to dry up considerably.<sup>126</sup> Noah then knew that the water had subsided from the earth and it was time to prepare to disembark. By choosing to pluck an olive leaf, the dove intimated that it would rather receive food as bitter as olives directly from God than more palatable food from the hand of a human.

12 He waited yet another seven days, until the 2<sup>nd</sup> of Tishrei, and sent out the dove, and this time it never again returned to him.

13 In the year 1657, which was the six-hundred-and-first year of Noah's life, on the first day of Tishrei, the first month, the waters had drained off the earth. Noah removed the covering of the ark and looked, and saw that the earth's surface was drying, although it was still too damp to live on.

14 By the twenty-seventh day of Marcheshvan, the second month, the earth was completely dry. This was exactly one solar year (365 days) since the rain had first begun to fall, on the 17<sup>th</sup> of Marcheshvan. The Flood purified the world of its spiritual defilement and coarseness. For the first time,<sup>127</sup> the world became receptive to the process of self-initiated refinement. From this point on, it would be relatively easy to ascend the ladder of spiritual self-refinement and repent for misdeeds.<sup>128</sup>

---

∞ CHASIDIC INSIGHTS ∞

---

The exile can be compared to the Flood: just as the Flood created disorder and displacement,<sup>129</sup> so, too, the exile sows spiritual disorder and confusion.

The "true colors" of the world, i.e., the underlying Divine energy that sustains everything, is not openly visible in the physicality of this world. We cannot see that God's presence fills the earth<sup>130</sup> or that the world's true and ultimate purpose is to be a home for God. All of these truths are obscured.<sup>131</sup> But the ultimate end of this "flood" of confusion is the removal of all impurity from the world,<sup>132</sup> making it a pure and perfected

world that will never again experience the "flood" that is exile.<sup>133</sup>

Yet even before that time comes, as we begin to sense that the floodwaters have subsided and that the time has arrived to emerge from the ark and behold a new world, we must do all we can to hasten the redemption.

Although, in the final analysis, it is God Himself who will bring the exile to an end, we should not await it passively. When God sees that we are actively yearning for the redemption and doing all in our power to hasten its immediate arrival, with our impassioned out-

---

126. *Likutei Sichot*, vol. 10, pp. 30-35. 127. With the exception of the Garden of Eden; see above, 2:14. 128. *Likutei Sichot*, vol. 15, pp. 52-54. 129. Above, 6:17. 130. See Isaiah 6:3. 131. See Isaiah 5:20. 132. See Zachariah 13:2. 133. See *Mechilta*, Exodus 15:1.

ONKELOS

15 ומליל יי עם נח למימר:  
 16 פוק מן תבותא את ואתתך  
 ובניך ונשי בניך עמך: 17 כל  
 חיותא דעמך מכל בשרא בעופא  
 ובבעירא ובכל רחשא דרחש  
 על ארעא אפק עמך ויתילדון  
 בארעא ויפשוו ויסגון על ארעא:  
 18 ונפק נח ובנוהי ואתתה ונשי  
 בנוהי עמה: 19 כל חיותא כל  
 רחשא וכל עופא כל דרחש  
 על ארעא לורעיתהון נפקו מן  
 תבותא: 20 ובנא נח מןבזא  
 קדם יי ונסיב מכל בעירא דכיתא  
 ומכל עופא דכיא ואסק עלון  
 על מדבזא: 21 וקבל יי ברעוא  
 ית קרבנה ואמר יי במימרה  
 לא אוסף למילט עוד ית ארעא  
 בדיל חובי אנשא ארי וצרא לכא  
 דאנשא ביש מועירה ולא אוסיף  
 עוד לממחי ית כל דחי כמא  
 דעבדית:

רביעי 15 וידבר אלהים אל־נח לאמר: 16 צא מן  
 התבה אתה ואשתך ובניך ונשי־בניך אתך: 17 כל־  
 החיה אשר־אתך מכל־בשר בעוף ובבהמה ובכל־  
 הרמש הרמש על־הארץ הוצא {היצא} אתך ושרצו  
 בארץ ופרו ורבו על־הארץ: 18 ויצא־נח ובניו ואשתו  
 ונשי־בניו אתו: 19 כל־החיה כל־הרמש וכל־העוף כל  
 רמש על־הארץ למשפחתיהם יצאו מן־התבה: 20 ויבן  
 נח מזבח ליהוה ויקח מכל הבהמה הטהרה ומכל  
 העוף הטהור ועל עלת במזבח: 21 וירח יהוה את־ריח  
 הניחח ויאמר יהוה אל־לבו לא אסף לקלל עוד את־  
 האדמה בעבור האדם כי יצר לב האדם רע מנעריו  
 ולא־אסף עוד להכות את־כל־חי באשר עשיתי:

RASHI

ברוך הוא להכניס מאלו שבועה שבועה, אלא כדי  
 להקריב קרבן מהם: 21 מנעריו. "מנערי" כתיב,  
 משננער לצאת ממעי אמו נתן בו יצר הרע: לא אסף  
 ולא אסף. כפל הדבר לשבועה, הוא שבתובי: "אשר  
 נשבעתו מעבר מי נח", ולא מצינו כה שבועה אלא זו,  
 שפפל דבריו והיא שבועה. וכן דרשו חכמים במסכת  
 "שבועות":<sup>400</sup>

16 אמה ואשתך וגו'. איש ואשתו. כאן התיר להם  
 תשמיש המטה: 17 הוציא. "הוציא" כתיב, "הוציא"  
 קרי. "היצא" — אמר להם שיצאו, "הוציא" — אם  
 אינם רוצים לצאת הוציאם אתה: ושרצו בארץ. ולא  
 בתבה, מגיד שאף הבהמה והעוף נאסרו בתשמיש:  
 19 למשפחתיהם. קבלו עליהם על מנת לדבק במינו:  
 20 מכל הבהמה הטהרה. אמר: לא צוה לי הקדוש

39. ישעיה נד, ט. 40. לו, א. השירים ה, ב.

CHASIDIC INSIGHTS

immersed in words of study and prayer, should influence our behavior outside it. But this will occur only if, during prayer and study, we remain completely oblivious to the existence of the world and only aware of Godliness. (Similarly, during the original ark's journey, the world was relatively "non-existent" since it was submerged underwater; even the planets had ceased revolving in their orbits.<sup>145</sup>) Then, when we emerge from our ark and enter the world, we will behold, like Noah did, "a new world," and be ready to fulfill our mission in it.<sup>146</sup>

**You may now resume marital relations:** This command—the first given to Noah in connection with leaving the ark—was meant not just to release Noah and the animals from the prohibition of cohabitation that had been in effect while in the ark, but also to convey the purpose of their leaving the ark. After the Flood obliterated all that was on the earth, it was Noah's job

to rebuild it through being fruitful and multiplying and ensuring that the animals did the same.

Procreation reveals God's infinite power here in this world, since it can potentially perpetuate a species from one generation to the next *ad infinitum*. Even though the ark was a lofty spiritual environment—or rather, precisely because it was so lofty and spiritual—it was not the place where God's infinite essence could dwell. It is only in the mundane world that we share in the experience of infinity by creating a home for God's infinite essence. This is why procreation, a reflection of God's infinite power, could not occur in the ark, but only outside it.<sup>147</sup>

**21 God smelled the appeasing fragrance:** The Midrash tells us that God smelled the fragrance of those who, in the future, would dedicate themselves to their Divine mission even to the point of self-sacrifice.<sup>148</sup> It then cites three examples: (a) Abraham, who, while in

144. Likutei Sichot, vol. 25, pp. 32-33. 145. Y. Pesachim 1:1; Bereishit Rabbah 25:2 and 34:11. 146. Likutei Sichot, vol. 1, pp. 9-10. 147. Likutei Sichot, vol. 25, pp. 31-32. 148. Bereishit Rabbah 34:9.

## Leaving the Ark

◆ *Fourth Reading* 15 Neither Noah nor the animals wanted to leave the ark, for they knew that once they did, the animals would revert to their naturally aggressive behavior. Their peaceful coexistence was a taste of the heightened spiritual state of the messianic future.<sup>136</sup> Therefore,<sup>137</sup> **God spoke to Noah, saying,**

16 **“Leave the ark,** despite the spiritual descent you will undergo by doing so. Furthermore, you may now resume marital relations: **you may live together with your wife, and your sons may live together with your son’s wives.**

17 **All living creatures from all flesh—birds, livestock, and all the reptiles that crawl upon the ground—tell them to leave with you,** and if they prefer to stay in the ark, take them out forcibly. Outside the ark, **they will be allowed<sup>138</sup> to teem on the earth, and be fruitful and multiply on the earth.”**

18 **Noah went out,** but he did not resume marital relations. He continued to live together **with his sons, and his wife** continued to live **with his sons’ wives.** Noah was reluctant to have more children, for he was afraid that history might repeat itself: humanity might again sin and bring upon itself another flood. What was the purpose of repopulating the world if it might ultimately be destroyed?<sup>139</sup>

19 **All the beasts, all the reptiles, all the birds, all the creatures that crawl upon the ground came out of the ark by families.** They reaffirmed their commitment<sup>140</sup> not to engage in crossbreeding.

20 **Noah** correctly intuited that God had commanded him to take an additional number of ritually pure animals to offer them as sacrifices when he left the ark. So he **built an altar to God. He took some of every species of ritually pure livestock and of every kind of ritually pure bird, and he offered them up as ascent-offerings on the altar.** An ascent-offering is one in which the meat of the animal is entirely consumed by fire on an altar.<sup>141</sup>

21 **God** figuratively **smelled the appeasing fragrance, and God said to Himself,** “I hereby swear that **I will never again curse the soil because of humanity, for the inclination of a person’s heart is challenged by his evil inclination from his earliest youth, i.e., from birth. Never again will I strike down all life as I have done.**

---

### ∞ CHASIDIC INSIGHTS ∞

---

This is what is meant by a *complete* year, the synthesis of sun and moon. When we go into “lunar mode,” the descent into the “floodwaters” of our mundane, worldly activities, we must also illuminate them with the “sun,” the self-illuminating acts of studying the Torah and observing the commandments.<sup>142</sup>

16 **Leave the ark:** As we have seen, “entering the ark” is a metaphor for enveloping oneself in the words of Torah study and prayer. It may be tempting to remain in this protective spiritual atmosphere, and its serene perfection might delude us into thinking that there really is no need to perfect the world around us. We are nevertheless instructed to leave it, for the true purpose of entering the ark is to ultimately emerge from it, en-

ter the world, and transform it into God’s home. (This is reflected in the law that one only becomes purified through immersion in a *mikveh* after having *emerged* from its waters.<sup>143</sup>)

We should not view the departure from our personal ark as self-sacrifice for the sake of others, since leaving the ark benefits and completes us, as well. As lofty as the levels we can attain in our own arks may be, they are nonetheless finite. Such levels are incomparable to the levels we can reach through our work in the “real world,” in which God provides us with the opportunity to share in the experience of infinity by creating a home for His infinite essence.<sup>144</sup>

The time that we spend inside our own personal ark,

---

135. See Isaiah 11:6. 136. *Likutei Sichot*, vol. 25, pp. 28-31. 137. See above, 6:18. 138. *Likutei Sichot*, vol. 25, p. 34. 139. See above, 6:20. 140. Leviticus 1:9, etc. 141. *Avot* 3:3. 142. *Likutei Sichot*, vol. 20, pp. 288-291. 143. *Mishneh Torah, Avot HaTumah* 6:16; see *Kesef Mishnah ad loc.*; *Likutei Sichot*, vol. 1, p. 14.



22 As long as the earth lasts, none of the seasons—seedtime and harvest, cold and heat, summer and winter (see figure 9)—nor day and night, will ever cease.”<sup>149</sup>

9:1 God blessed Noah and his sons and said to them, “Be fruitful and multiply, and fill the earth. I promise you that you will be fertile.<sup>150</sup> As for your fear about having more children, I tell you now that I have promised not to destroy the world again.

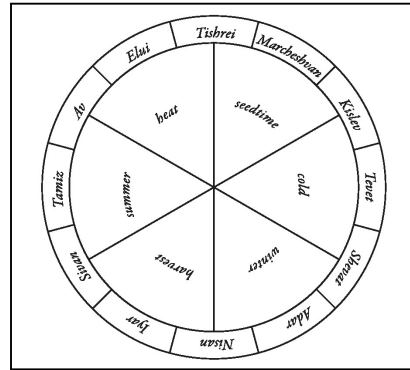

Figure 9: The Seasons

### CHASIDIC INSIGHTS

the court of Nimrod, chose to be forced into a fiery furnace rather than accept idolatry (and was subsequently miraculously saved);<sup>151</sup> (b) Chananiah, Mishael, and Azariah, who, while in the court of Nebuchadnezzar, acted in the same manner as Abraham;<sup>152</sup> and (c) those of our pre-messianic generation who, despite living under conditions of intolerable persecution, would nonetheless remain passionately committed to their Divine mission.

Chananiah, Mishael, and Azariah exhibited greater self-sacrifice than Abraham, since God’s presence was more hidden in their time than it was in Abraham’s. Idolaters had invaded and desecrated God’s Temple and the Jewish people were in exile.<sup>153</sup> Yet despite this challenge to their faith, they remained committed to God.

But our generation has shown even greater self-sacrifice, since it follows a lengthy exile, rife with horrific persecutions. This generation can surely ask: “How is it possible that all we’ve already suffered through is not enough? Why are we still languishing in an exile that is so permeated with intense spiritual darkness? We have witnessed so many horrific occurrences that cannot possibly be explained in any way. We see that even those who fulfilled God’s commandments—which should certainly have afforded them His pro-

tection<sup>154</sup>—have unfortunately met with unspeakable fates.” And yet, despite God’s nearly-total concealment, many of this generation have remained unflinchingly committed to their Divine mission. Indeed, when Moses foresaw this generation, he was humbled.<sup>155</sup>

And it was indeed the sweet fragrance of these very individuals from our generation that “inspired” God to promise that day and night would never again cease:

It is not within the capacity of nature to be eternal and unchanging. Therefore, God’s promise that the laws of nature would *not* cease means that it would be imbued with the Godly attribute of infinity and immutability, as expressed in the verse: “I am God; I have not changed.”<sup>156</sup>

(Once nature became constant, it became a reflection of God’s eternal and immutable essence. In this aspect, interestingly, nature serves as a more precise reflection of God’s greatness than do miracles.)

When God saw those who would continue to engage in their spiritual work with self-sacrifice and unabated enthusiasm despite His concealment, and that their commitment would be stable and unchanging, He correspondingly endowed nature with the same stability.<sup>157</sup>

(Parenthetically, Noah’s offerings resembled self-sacrifice. When we offer a sacrifice, we are intended to

### A CLOSER LOOK

**[22] Seedtime and harvest...day and night will not cease:** As mentioned above,<sup>158</sup> God’s promise after the Flood to never again destroy humanity gave the world a strength and stability it did not previously possess. Still, even after this promise, miraculous phenomena continued to occur, as exceptions to the rule.

The dichotomy between the stability of nature and individual miraculous events is reflected in the dichotomy between the six days of the workweek

and the Sabbath.<sup>159</sup> Similarly, the sun, whose light is constant, alludes to that which contravenes nature’s constancy, namely, miracles. Therefore, since our holidays commemorate miraculous events and revelations of Godliness that transcended nature, they fall on a particular day of the month, whose beginning and end is determined by the orbit of the moon, and not on a particular day of the week, whose beginning and end is determined by seven consecutive orbits of the sun.<sup>160</sup>

149. See above, 7:10. 150. Rashi on 9:7, below; see *Likutei Sichot*, vol. 30, p. 28, note 44. 151. Below, 11:28. 152. Daniel 3:1-30; 1:7. 153. *Yoma* 69b. 154. *Pesachim* 8b. 155. *Sefer HaMa’amarim* 5679, p. 464. 156. Malachi 3:6. 157. *Likutei Sichot*, vol. 20, p. 35; *Sefer HaMa’amarim* 5740, p. 38-39. 158. On v. 21. 159. See Inner Dimensions on this verse. 160. *Likutei Sichot*, vol. 27, p. 45.

ONKELOS

2 וְדַחַלְתְּכוֹן וְאֵימְתְּכוֹן תְּהִי עַל כָּל חַיּוֹת אֶרֶץ וְעַל כָּל עוֹפֵי דְשָׁמַיִם בְּכָל הַיּוֹם תִּרְחִישׁ אֶרֶץ וּבְכָל נוֹיֵי יָמָּה בְּיַדְכֶם נִתְּנוּ: 3 כָּל רִחְשָׁא דְהוּא חַי לְכוּן יְהִי לְמִיכַל בִּירוּק עֲשָׂבָא יְהִיבִית לְכוּן יְת כָּלָא: 4 בְּרַם בְּשָׂרָא בְּנִפְשָׁה דְמָה לָא תִיבְלוּן: 5 וּבְרַם יְת דְמִכּוּן לְנִפְשָׁתְכוֹן אֲתַבַּע מִיַּד כָּל חַיּוֹתָא אֲתַבַּעֵנָה וּמִיַּד אֲנִשָׂא מִיַּד גְּבַר דְיִשׁוּד יְת דְמָא דְאָחוּדֵי אֲתַבַּע יְת נִפְשָׁא דְאֲנִשָׂא: 6 דְיִשׁוּד דְמָא דְאֲנִשָׂא בְּסִדְדִין עַל מִימַר דְיִנְיָא דְמָה יְתִשָׁד אַרְי בְּצַלְם אֱלֹהִים עֲבַד יְת אֲנִשָׂא:

2 וּמוֹרְאֵכֶם וְהִתְכֶם יִהְיֶה עַל כָּל־חַיֵּי הָאָרֶץ וְעַל כָּל־  
 עוֹף הַשָּׁמַיִם בְּכָל אֲשֶׁר תִּרְמַשׁ הָאֲדָמָה וּבְכָל־דְּגֵי  
 הַיָּם בְּיַדְכֶם נִתְּנוּ: 3 כָּל־לְרֵמֶשׂ אֲשֶׁר הוּא־חַי לָכֶם יִהְיֶה  
 לְאֹכְלָהּ כִּי־רַק יֵעָשֶׂב נִתְּתִי לָכֶם אֶת־כָּל: 4 אֶדְ-בְּשָׂר  
 בְּנִפְשׁוֹ דָּמוֹ לֹא תֹאכְלוּ: 5 וְאֵף אֶת־דַּמְכֶם לְנִפְשַׁתִּיכֶם  
 אֲדַרְשׁ מִיַּד כָּל־חַיָּה אֲדַרְשְׁנָהּ וּמִיַּד הָאָדָם מִיַּד אִישׁ  
 אָחִיו אֲדַרְשׁ אֶת־נִפְשׁ הָאָדָם: 6 שִׁפְךָ דָּם הָאָדָם כַּאֲדָם  
 דָּמוֹ יִשְׁפָּךְ כִּי בְּצַלְם אֱלֹהִים עָשָׂה אֶת־הָאָדָם:

RASHI

יָצָא מִמֶּנּוּ דָם: מִיַּד כָּל חַיָּה. לְפִי שְׁחֻטָּאוֹ דוֹר הַמַּבּוּל  
 וְהִפְקְרוּ לְמֹאכַל חַיּוֹת רְעוּת לְשֹׁלֵט בָּהֶן, שֶׁנֶּאֱמַר:  
 "נִמְשַׁל בְּבַהֲמוֹת נְדָמוֹ", לְפִיכָף הִצְרָף לְהוֹדִיר עֲלֵיהֶן  
 אֶת הַחַיּוֹת: וּמִיַּד הָאָדָם. מִיַּד הַהוֹרֵג בְּמוֹיֵד וְאִין עֵדִים,  
 אֲנִי אֲדַרְשׁ: מִיַּד אִישׁ אָחִיו. מִיַּד שֶׁהוּא אוֹהֵב לוֹ כַּאֲח  
 וְהִרְגוֹ שׁוֹגֵג, אֲנִי אֲדַרְוֵשׁ אִם לֹא יִגְלָה וַיִּבְקֶשׂ עַל עֹנּוֹ  
 לְמַחֵל, שֶׁאֵף הַשׁוֹגֵג צְרִיף כְּפָרָה. וְאִם אִין עֵדִים לְחִיבּוֹ  
 גְלוּת, וְהוּא אִינוֹ נִכְנָע, הַקְּדוֹשׁ בְּרוּךְ הוּא דוֹרֵשׁ מִמֶּנּוּ.  
 כְּמוֹ שֶׁדַּרְשׁוֹ רַבּוֹתֵינוּ וְכוּנֵם לְבָרְכָה: "וְהֵאֱלֹהִים אָנָּה  
 לְיָדוֹ",<sup>47</sup> בְּמִסְכַּת "מַכּוֹת"<sup>48</sup>: הַקְּדוֹשׁ בְּרוּךְ הוּא מוֹמְנֵן  
 לְפָנֶיךָ אֶחָד וְכוּ': 6 בְּאָדָם דָּמוֹ יִשְׁפָּךְ. אִם יֵשׁ עֵדִים —  
 הַמֵּיתוּהוּ אִתָּם, לְמָה? "כִּי בְּצַלְם אֱלֹהִים" וְגו': עָשָׂה אֶת  
 הָאָדָם. זֶה מִקְרָא חֶסֶד, וְצְרִיף לְהַיּוֹת: "עָשָׂה הַעוֹשֶׂה אֶת  
 הָאָדָם", וְכֵן הִרְבֵּה בְּמִקְרָא:

2 וְהִתְכֶם. וְאֵימְתְּכֶם, כְּמוֹ<sup>44</sup>: "תִּרְאוּ חַתַּת". וְאִגְדָּה:<sup>45</sup>  
 לְשׁוֹן "חַיּוֹת", שֶׁכָּל זְמַן שֶׁהִתְיַוֵּק בֶּן יוֹמוֹ חַי, אִין אֲתָה  
 צְרִיף לְשִׁמְרוֹ מִן הַעֲכָבְרִים. עוֹג מְלַף הַבֶּשֶׂן מֵת, צְרִיף  
 לְשׁוֹמְרוֹ מִן הַעֲכָבְרִים, שֶׁנֶּאֱמַר: "וּמוֹרְאֵכֶם וְהִתְכֶם  
 יִהְיֶה" — אֵימְתִי יִהְיֶה מוֹרְאֵכֶם עַל הַחַיּוֹת, כָּל זְמַן  
 שֶׁאֲתֵם חַיִּים: 3 לָכֶם יִהְיֶה לְאֹכְלָהּ. שֶׁלֹּא הִרְשִׁיתִי  
 לְאָדָם הִרְאִשׁוֹן לְאֹכַל בְּשָׂר אֶלָּא יִרַק עֵשֶׂב, וְלָכֶם —  
 "כִּי־רַק עֵשֶׂב" שֶׁהִפְקַרְתִּי לְאָדָם הִרְאִשׁוֹן, נִתְּתִי לָכֶם  
 אֶת כָּל: 4 בְּשָׂר בְּנִפְשׁוֹ. אֶסֶר לָהֶם אֲבָר מִן הַחַי,  
 כְּלוּמַר כָּל זְמַן שֶׁנִּפְשׁוֹ בּוֹ לֹא תֹאכְלוּ הַבְּשָׂר: בְּנִפְשׁוֹ  
 דָּמוֹ. בְּעוֹד נִפְשׁוֹ בּוֹ: בְּשָׂר בְּנִפְשׁוֹ לֹא תֹאכְלוּ. הִרִי  
 אֲבָר מִן הַחַי. וְאֵף "בְּנִפְשׁוֹ דָּמוֹ לֹא תֹאכְלוּ" — הִרִי דָם  
 מִן הַחַי: 5 וְאֵף אֶת דַּמְכֶם. אֵף עַל פִּי שֶׁהִתְרַתִּי לָכֶם  
 נְטִילַת נִפְשָׁה בְּבַהֲמָה, אֶת דַּמְכֶם אֲדַרְוֵשׁ מִהַשׁוֹפֵף דָּם  
 עֲצָמוֹ: לְנִפְשַׁתִּיכֶם. אֵף הַחוֹזֵק עֲצָמוֹ, אֵף עַל פִּי שֶׁלֹּא

44. איוב ו, כא. 45. בראשית רבה לד, יב. 46. תהלים מט, יג. 47. שמות כא, יג. 48. י, ב.

CHASIDIC INSIGHTS

true in our post-Holocaust generation: after witnessing the obliteration of a massive segment of our people, the first-and-foremost obligation incumbent upon the survivors and their descendants, and their holy privilege as well, is to rebuild the Jewish people physically.<sup>178</sup> We should not be satisfied with the minimum number required by Torah law, namely one son and one daughter: Maimonides rules that, as long as one is still physically able to bear more children, one should continue to do so.<sup>179</sup> This ruling is alluded to in the difference between God's command to Adam and His command

to Noah: Whereas Adam was commanded to procreate even *before* he had any children, Noah is here commanded to procreate *after* he already had fathered three children.

The same holds true for spiritual procreation, i.e., educating our pupils: We should not be satisfied with having taught pupils in our younger years; we must continue to educate new pupils as we grow older.<sup>180</sup>

178. Likutei Sichot, vol. 25, p. 33. 179. Mishneh Torah, Ishut 15:16. 180. Likutei Sichot, vol. 30, pp. 28-29.

2 Furthermore, neither do you need to be concerned that your offspring's lives will be endangered. As it was before the degeneration of humanity prior to the flood,<sup>172</sup> **there shall be a fear and dread of you upon all the beasts of the earth and upon all the birds of the sky, in all that will crawl on the land and in all the fish of the sea.** They will no longer try to devour you when you are alive. Rather, **they have been placed in your hand:**

3 **Every moving creature that lives shall be yours to eat; like plant vegetation, I have now given you everything.** Until now, I forbade humanity from killing animals for food, because I was afraid that, given this power over life and death, people would delude themselves into thinking that they had godlike dominion over the world.<sup>173</sup> But because humanity has become weaker and needs to eat meat to subsist, I am allowing these health considerations to override this former prohibition.<sup>174</sup> Also, because the spiritual makeup of the world is now more conducive to self-refinement, there is less danger of you becoming coarsened by eating meat.<sup>175</sup>

4 **But nevertheless, you may not eat the flesh** of a still-living creature, **nor its blood.**

5 Although I have allowed you to kill animals, **nevertheless**, do not think that I have given you absolute power over life and death, not even your own. In fact, you may not even cause yourselves to bleed unnecessarily;<sup>176</sup> if you do, **I will settle the account of the blood** you shed by punishing you. If you take **your own lives** by committing suicide—even without shedding blood, as, for example, by strangulation—I will punish you in the afterlife.

Human life is so precious that, now that I have again forbidden the animals to kill you, **I will settle the account from the hand of every wild beast** that kills one of you, by killing it in turn.<sup>177</sup>

Neither may you kill other people. I will empower the courts to punish anyone who commits a witnessed act of murder: intentional murder is to be punishable by death and unintentional manslaughter is to be punishable by exile. **I will settle the account for human life** Myself whenever the courts cannot, both **from someone** who commits an intentional but unwitnessed murder and **from someone** who commits unintentional manslaughter—i.e., who is on as good terms with his victim as he is with his **own brother** but kills him accidentally. I will arrange for the accidental manslayer to accidentally kill the murderer in the presence of witnesses; thus the murderer will receive his death penalty and the court will sentence the manslayer to exile to atone for his carelessness. If, however, the unwitnessed manslayer goes into exile voluntarily, I will arrange for the murderer to be killed in another fashion.

6 In contrast, **whoever** intentionally **sheds human blood**, was warned not to do so, and was witnessed doing so, **his blood shall be shed by the human court, for God made man in the image of God.** The murderer is guilty of diminishing the image of God on earth and has thus forfeited his right to live.

172. Above, 6:2. Rashi on 4:15. 173. See above, 1:29. 174. *Likutei Sichot*, vol. 20, p. 11. 175. *Likutei Sichot*, vol. 15, p. 53, note 37. 176. *Likutei Sichot*, vol. 5, p. 146. 177. Abarbanel.

ONKELOS

7 וְאֵתָם פָּרוּ וּרְבוּ שָׂרְצוּ בְּאֶרֶץ וּרְבוּ בָהֶ: 8 חֲמִישִׁי 9 וְאֵנִי הִנְנִי מְקִים אֶת־בְּרִיתִי אִתְּכֶם וְאֶת־זִרְעֵכֶם אֲחֲרֵיכֶם: 10 וְאֵת כָּל־נֶפֶשׁ הַחַיָּה אֲשֶׁר אִתְּכֶם בְּעוֹף בְּבִהֵמָה וּבְכָל־חַיַּת הָאָרֶץ אִתְּכֶם מִכָּל יִצְאֵי הַתְּהוֹמָה לְכָל חַיַּת הָאָרֶץ: 11 וְהִקְמַתִּי אֶת־בְּרִיתִי אִתְּכֶם וְלֹא־יִפָּרֵת כָּל־בְּשָׂר עוֹד מִמֵּי הַמַּבּוּל וְלֹא־יִהְיֶה עוֹד מַבּוּל לְשִׁחַת הָאָרֶץ:

7 וְאֵתָם פָּרוּ וּרְבוּ שָׂרְצוּ בְּאֶרֶץ וּרְבוּ בָהֶ: 8 חֲמִישִׁי 9 וְאֵנִי הִנְנִי מְקִים אֶת־בְּרִיתִי אִתְּכֶם וְאֶת־זִרְעֵכֶם אֲחֲרֵיכֶם: 10 וְאֵת כָּל־נֶפֶשׁ הַחַיָּה אֲשֶׁר אִתְּכֶם בְּעוֹף בְּבִהֵמָה וּבְכָל־חַיַּת הָאָרֶץ אִתְּכֶם מִכָּל יִצְאֵי הַתְּהוֹמָה לְכָל חַיַּת הָאָרֶץ: 11 וְהִקְמַתִּי אֶת־בְּרִיתִי אִתְּכֶם וְלֹא־יִפָּרֵת כָּל־בְּשָׂר עוֹד מִמֵּי הַמַּבּוּל וְלֹא־יִהְיֶה עוֹד מַבּוּל לְשִׁחַת הָאָרֶץ:

RASHI

בְּרִית לְהִבְטָחָתִּי, וְאֵתָן לָךְ אוֹת: 10 חַיַּת הָאָרֶץ אִתְּכֶם. הֵם הַמֵּתֵהֱלָכִים עִם הַבְּרִיּוֹת: מִכָּל יִצְאֵי הַתְּהוֹמָה. לְהִבְיֵא שְׂקָצִים וּרְמָשִׁים: לְכָל חַיַּת הָאָרֶץ. לְהִבְיֵא הַמַּזְוִיקִין, שְׂאִינָן בְּכָל־ל "הַחַיָּה אֲשֶׁר אִתְּכֶם", שְׂאִין הַלּוֹכֵן עִם הַבְּרִיּוֹת: 11 וְהִקְמַתִּי. אֶעֱשֶׂה קִיּוּם לְבְּרִיתִי. וּמַהוּ קִיּוּמוֹ? "אֵת הַקְּשֶׁת", כְּמוֹ שְׂמֻסִּים וְהוֹלֵךְ:

7 וְאֵתָם פָּרוּ וּרְבוּ. לְפִי פְּשׁוּטוֹ: הִרְאֵנוּהָ לְבְּרָכָה, וְכֵן לְצִוּוֹי. וּלְפִי מִדְּרָשׁוֹ: לְהַקְיֵשׁ מִי שְׂאִינוֹ עוֹסֵק בְּפָרִיָּה וּרְבִיָּה לְשׁוֹפֵךְ דָּמִים: 9 וְאֵנִי הִנְנִי. מְסַבִּים אֲנִי עִמָּךְ, שְׁהִיָּה נָח דוֹאֵג לְעֶסוֹק בְּפָרִיָּה וּרְבִיָּה, עַד שֶׁהִבְטִיחוֹ הַקְּדוֹשׁ בְּרוּךְ הוּא שְׂלֵא לְשַׁחַת הָעוֹלָם עוֹד, וְכֵן עֲשֵׂה. וּבְאַחֲרוֹנָה אָמַר לוֹ: הִנְנִי מְסַבִּים לְעֲשׂוֹת קִיּוּם וְחֻזֵק

CHASIDIC INSIGHTS

proach the messianic age: According to the Talmud, the Messiah will not come until all the souls have descended from their heavenly "storehouse" and experienced life in this physical world.<sup>185</sup> Thus, every child that is born brings us one step closer to the messianic era.

There are, of course, exceptions to the rule. In some instances, the Torah actually forbids parents to have another child, usually because of severe health concerns or danger to life. Such cases must be brought before a competent rabbinic authority, and never be determined by our own subjective pessimistic apprehensions.<sup>186</sup>

**9 I am setting up My covenant with you:** The objective of this covenant was not solely the physical maintenance of the world. Its deeper intention was that the world operate in accordance with the ultimate purpose for which it was created,<sup>187</sup> that it assist the Jewish people in fulfilling its Divine mission. True, we have not yet seen the fulfillment of this promise; on the contrary, we have sadly suffered far too much and undergone far too horrific religious and physical persecution. Nevertheless, by clinging tenaciously to our heartfelt hopes and fervently praying that we should never again undergo or witness such horrors, while at the same time dedicating ourselves to our Divine mission with joy and alacrity, we can bring about the fulfillment of God's intention that the world assist us in our Divine mission. When that occurs, even those nations who

formerly persecuted us will be transformed into our allies.<sup>188</sup> **11 Never again will there be a flood to destroy the earth:** As we have seen,<sup>189</sup> in the supernal narrative, the Flood was a reversion to the initial state of creation, in which the earth was physically submerged under water and spiritually submerged in Divine awareness. From this perspective, God's promise to never again bring a flood seems puzzling: why shouldn't He?

The explanation is as follows: At the very beginning of creation, all was water because dry land did not yet exist.<sup>190</sup> On the spiritual level, this means that the world was filled with Divine awareness because dry land, which represents the façade of a self-sustained world independent of God, did not yet exist.

God's ultimate desire, however, is that Divine awareness permeate even a world with "dry land," i.e., self-awareness. Indeed, this will be the state of the world in the messianic age, when "the world will be filled with the knowledge of God like water covers the seabed."<sup>191</sup> At that time, even though the world will not be covered by water and we will still be in a state of self-awareness, we will nevertheless enjoy the Divine awareness normally associated with submersion under water, i.e., self-nullification.

However, for the earth to reach this stage, it first had to have been immersed in the waters of the Flood, which "destroyed the earth," i.e., which nullified the earth's

185. *Yevamot* 62a. 186. *Likutei Sichot*, vol. 25, pp. 34-37. 187. *Likutei Sichot*, vol. 20, p. 34. 188. *Sefer HaMa'amarim* 5740, p. 41. 189. On 7:12, above. 190. See *Korban HaEidah* on *Y. Chagigah* 2:1. 191. *Isaiah* 11:9.

7 **And as for you, I now command you: be fruitful and multiply, proliferate upon the earth, and make it populous.** If you or your descendants refrain from procreating, I will consider it tantamount to committing murder.”

In addition to what God explicitly commanded them, Noah’s children undertook to show honor to their parents and forswore licentiousness, understanding that these principles are the foundation of the just society that had been undermined by the generations preceding the Flood.<sup>181</sup>

◆ **Fifth Reading 8** Nonetheless, Noah was still hesitant to procreate, so **God spoke to Noah and to his sons with him again, saying,**

9 **“I hereby fortify My promise. I am establishing My covenant to seal My promise with you and with your offspring after you,**

10 **with every living creature that is with you—the birds, the livestock, and all the harmless beasts of the earth who live with you—with all crawling creatures who left the ark, and with every living being on earth that is harmful to human beings.**

11 **Furthermore, I will confirm My covenant with you by giving you a sign that I am bound by it, and thus you can rest assured that never again will any flesh be cut off by the waters of a flood. Never again will there be a flood that will destroy the earth or any part of it.”**

---

∞ CHASIDIC INSIGHTS ∞

---

8 **Noah was still hesitant to procreate:** Noah’s initial doubts were not completely allayed by God’s assurance. Even if his yet-to-be-born, hypothetically sinful descendants would not be *physically* destroyed, they would still be *spiritually* lost. (And surely Noah’s primary concern was for his children’s *spiritual* state.) Why, then, did God’s assurance succeed in changing Noah’s mind?

Like Noah, some people harbor doubts about the prudence of having children. They argue that raising children is an awesome responsibility. Some wonder whether they have the capacity to raise children who will grow into healthy adults, both physically and spiritually. Such people therefore focus on first achieving financial security and/or spiritual preparedness, and only then start thinking about having children.

But from Noah we learn the fallacy of this approach. Once God commanded him to have children, he no longer hesitated to procreate, despite his apprehensions about his descendants’ spiritual future. Because ultimately, it is not our job to predict the future but to fulfill God’s will. If God tells us to have children, we should not let our doubts prevent us from doing so.

Even if we somehow foresee a less-than-perfect spiritual future for our children, we would still not be justified in refraining from having them. King Hezekiah saw prophetically that he would have immoral chil-

dren and therefore refrained from procreating. The prophet Isaiah rebuked him for this, saying, “God’s mysteries are no business of yours. You must do what you are commanded.”<sup>182</sup>

Certainly, then, when we only entertain *uncertainties* about our children’s spiritual future, we should not refrain from fulfilling God’s command. (Furthermore, in Hezekiah’s case, we see that a number of very righteous kings eventually descended from him.)

We should also not be concerned about the financial responsibilities that raising children entails. Since God is the one who commands us to have children, it is axiomatic that, for each additional child born, He will open up an additional channel of blessing and sustenance.

Likewise, we should not worry that we might lack the physical or emotional strength to raise many children,<sup>183</sup> for God does not ask of us anything that is beyond our capabilities.<sup>184</sup> In fact, having many children actually promotes physical and spiritual wellbeing. In contrast to the popular notion that having many children is not conducive to living a calm and stable life, the truth is that having too *few* children is unnatural and can lead to anxiety, marital disharmony, and the disruption of family life.

All of the above has always held true, but its truth is especially relevant in our present generation, as we ap-

---

181. *Likutei Sichot*, vol. 5, p. 147; *ibid.*, p. 153, note 30, based on Rashi on 9:23, 11:32, 34:7, and 37:34, below. See also below, 38:26. 182. *Berachot* 10a. 183. See *Mishneh Torah*, *Ishut* 15:16. 184. *Bemidbar Rabbah* 12:3.

— ONKELOS —

12 וַיֹּאמֶר יי דא אַת קָיָם די אָנא יִהְיֶה בֵּין מִימְרֵי וּבִינִיכּוֹן וּבִין כָּל נִפְשָׁא חַיָּתָא די עִמְכוֹן לְדָרֵי עֲלָמָא: 13 יְת קִשְׁתִּי יִהְיֶית בַּעֲנָנָא וְתִהִי לְאֵת קָיָם בֵּין מִימְרֵי וּבִין אַרְעָא: 14 וְיִהִי בַּעֲנֻנְתִּי עֲנָנָא עַל אַרְעָא וְתִתְחַזֵּי קִשְׁתָּא בַּעֲנָנָא: 15 וְאֲדַפֵּר יְת קָיָמִי דִּי בֵּין מִימְרֵי וּבִינִיכּוֹן וּבִין כָּל נִפְשָׁא חַיָּתָא בְּכָל בְּשָׂרָא וְלֹא יִהִי עוֹד מִיָּא לְטוֹפְנָא לְחַבְלָא כָּל בְּשָׂרָא: 16 וְתִהִי קִשְׁתָּא בַּעֲנָנָא וְאֲחֻזָּה לְדַכְרֹן קָיָם עַלְמָם בֵּין מִימְרֵי דִּי וּבִין כָּל נִפְשָׁא חַיָּתָא בְּכָל בְּשָׂרָא דִּי עַל אַרְעָא: 17 וַיֹּאמֶר יי לְנֹחַ דָּא אַת קָיָם דִּי אַקִּימִית בֵּין מִימְרֵי וּבִין כָּל בְּשָׂרָא דִּי עַל אַרְעָא: 18 וְהוּוּ בְנֵי נֹחַ דִּי נִפְקוּ מִן תְּבוּלָתָא שָׁם וְחָם וְיֹפֶת וְחָם הוּא אָבִיהֶי דְכְנַעַן:

12 וַיֹּאמֶר אֱלֹהִים זֹאת אֹת־הַבְּרִית אֲשֶׁר־אֲנִי נֹתֵן בֵּינִי וּבֵינֵיכֶם וּבֵין כָּל־נֶפֶשׁ חַיָּה אֲשֶׁר אִתְּכֶם לְדֹרֹת עוֹלָם: 13 אֶת־קִשְׁתִּי נֹתַתִּי בַּעֲנָן וְהִיְתָה לְאֹת בְּרִית בֵּינִי וּבֵין הָאָרֶץ: 14 וְהָיָה בַּעֲנָנִי עָנָן עַל־הָאָרֶץ וְנִרְאָתָה הַקִּשְׁתׁ בַּעֲנָן: 15 וְזָכַרְתִּי אֶת־בְּרִיתִי אֲשֶׁר בֵּינִי וּבֵינֵיכֶם וּבֵין כָּל־נֶפֶשׁ חַיָּה בְּכָל־בְּשָׂר וְלֹא־יְהִיָּה עוֹד הַמַּיִם לְמַבּוּל לְשַׁחַת כָּל־בְּשָׂר: 16 וְהִיְתָה הַקִּשְׁתׁ בַּעֲנָן וְרִאִיתִיהָ לְזָכֹר בְּרִית עוֹלָם בֵּין אֱלֹהִים וּבֵין כָּל־נֶפֶשׁ חַיָּה בְּכָל־בְּשָׂר אֲשֶׁר עַל־הָאָרֶץ: 17 וַיֹּאמֶר אֱלֹהִים אֶל־נֹחַ זֹאת אֹת־הַבְּרִית אֲשֶׁר הִקְמַתִּי בֵּינִי וּבֵין כָּל־בְּשָׂר אֲשֶׁר עַל־הָאָרֶץ: פ  
שׁוּי 18 וְיִהְיוּ בְנֵי־נֹחַ הַיְצְאִים מִן־הַתֵּבָה שֵׁם וְחָם וְיֹפֶת וְחָם הוּא אָבִי כְנַעַן:

— RASHI —

לְקַטְרֵג עֲלֵיכֶם לְחַיֵּב אֶתְכֶם, אֲנִי רוֹאֶה אֶת הָאוֹת וְנֹכְרֵי: 17 זֹאת אֹת הַבְּרִית. הִרְאָהוּ הַקִּשְׁתׁ, וַיֹּאמֶר לוֹ: הֲרִי הָאוֹת שְׂאֵמְרָתִי: 18 וְחָם הוּא אָבִי כְנַעַן. לְמַה הִצְרִיף לוֹמֵר כֵּן? לְפִי שֶׁהִפְרָשָׁה עֲסוּקָה וּבָאָה בְּשִׁכְרוֹתוֹ שֶׁל נֹחַ שֶׁקִּלְקַל בָּהּ חָם, וְעַל יָדוֹ נִתְקַלַּל כְּנַעַן, וְעַדִּין לֹא כָּתַב תּוֹלְדוֹת חָם וְלֹא יִדְעֵנוּ שֶׁכְּנַעַן בְּנוֹ, לְפִיכֵף הִצְרִיף לוֹמֵר כֵּן: "וְחָם הוּא אָבִי כְנַעַן":

12 לְדֹרֹת עוֹלָם. נִכְתַּב חֶסֶר, שֵׁישׁ דּוֹרוֹת שֶׁלֹּא הִצְרִיכוּ לְאוֹת, לְפִי שֶׁצְדִיקִים גְּמוּרִים הָיוּ, כְּמוֹ דּוֹרוֹ שֶׁל חֻזְקִיהוּ מֶלֶךְ יְהוּדָה, וְדוֹרוֹ שֶׁל רַבִּי שְׁמַעוֹן בֶּן יוֹחָאי: 14 בַּעֲנָנִי עָנָן. כְּשֶׁתְּעַלֶּה בְּמַחֲשָׁבָה לְפָנַי לְהִבִּיא חֶשֶׁךְ וְאֲבִדוֹן לְעוֹלָם: 16 בֵּין אֱלֹהִים וּבֵין כָּל נֶפֶשׁ חַיָּה. בֵּין מִדַּת הַדִּין שֶׁל מַעֲלָה וּבִינֵיכֶם, שֶׁהָיָה לוֹ לְכַתֵּב: "בֵּינִי וּבֵין כָּל נֶפֶשׁ חַיָּה", אֲלֵא וְהוּוּ מִדְּרָשׁוֹ: כְּשֶׁתְּבֵא מִדַּת הַדִּין

— CHASIDIC INSIGHTS —

sense of self. This one-time experience conditioned the earth to be able to later attain Divine awareness—even after the waters receded and the earth reverted to dry land. The Midrash<sup>197</sup> therefore compares the messianic age to the days of Noah, since the Flood initiated the process of conditioning the world for its ultimate state—Divine awareness despite the presence of self—which it will attain in the messianic age.

Once this conditioning occurred, God promised never to Flood the earth again, in keeping with His original intention for the world to exist in its "natural" state and still be a vessel for Divine awareness.

In fulfilling our own Divine mission on earth, we also experience a period of immersion in the waters of Divine awareness: the High Holy Days of the month of Tishrei. Our challenge is to successfully experience Divine awareness even after Tishrei, when the "waters

have receded" and our "dry" self has emerged.<sup>198</sup>

**18 Ham was the father of Canaan:** *Ham* means "hot." Metaphorically, Ham alludes to the soul's ardent desire and yearning to draw near and cleave to God.

*Canaan*, which is sometimes translated as "merchant,"<sup>199</sup> alludes to the soul's pursuit of the profit it earns by studying the Torah and observing the commandments: its increased connection to God.

*Ham was the father of Canaan:* When the soul descends into this world and clothes itself in the body and the animating soul, it experiences an intense longing for Godliness and an ardent yearning for God's presence—it becomes *Ham*. This longing inspires it to earn the reward of increased connection to God by studying the Torah and performing the commandments—to become *Canaan*.<sup>200</sup>

197. *Vayikra Rabbah* 7:4. 198. *Likutei Sichot*, vol. 30, pp. 21-23. 199. See Isaiah 23. 200. *Torah Or* 27a.

12 God said, "This is the sign that I am providing for the covenant between Me and you and every living creature that is with you, for all generations that require it (i.e., the sign, in case they themselves not be sufficiently righteous):

13 I have placed My rainbow in the clouds, and it shall be a sign of the covenant between Me and the world. As part of the overall refinement of reality effected by the Flood, the atmosphere will now be sufficiently purified to refract and reflect sunlight and thereby produce rainbows. The rainbow therefore testifies to the fact that the world is now sufficiently refined to afford the possibility of repentance. Since it is always possible for humanity to repent, it will never again be necessary to wipe out the world.<sup>192</sup>

14 Thus, **when** the behavior of any society in any locale degenerates to the point that I regret having created its inhabitants, and **I bring clouds over the earth** to indicate that they deserve that I bring a flood upon them, just as I did with *your* generation, **the rainbow will appear among the clouds,**

15 **and I will recall My covenant that exists between Me and you and every living creature among all flesh, so that never again shall the waters become a flood to destroy any flesh.** However, when *no* part of society is behaving that immorally, it will not be necessary for me to cause a rainbow to appear.<sup>193</sup>

16 In accordance with the transformation of My attribute of judgment into My attribute of mercy that began when you prayed to Me in the ark,<sup>194</sup> I will now extend the covenant I just established between us and apply it to My attribute of judgment, as well: Even when your conduct is wanting, and logically My attribute of judgment should raise an accusation against you, **the rainbow will be in the clouds, and I will see it to recall the eternal covenant** I am now making **between God's attribute of judgment and every living creature among all flesh that is upon the earth,** and I will not even allow My attribute of judgment to prosecute you."<sup>195</sup>

17 God said to Noah, showing him a rainbow, "**Behold the sign of the covenant that I have established between Me and all flesh that is upon the earth.**"

### Noah's Prophecy

- ◆ *Sixth Reading* 18 Having been promised by God that his progeny would not be wiped out, Noah resumed marital relations with his wife, as did his sons with their wives. **The sons of Noah who came out of the ark were Shem, Ham, and Japheth;** they each had a number of children. **Ham was the father of** four sons, the youngest of which was **Canaan.** Ham was incensed that his father, Noah, was trying to have more children. He assumed that Cain had killed his brother, Abel, because he wanted the whole world for himself. Since Noah was the new beginning of the human race, Ham considered himself already deprived enough by having to share the world with *two* other brothers, and should not be required to share it with any additional brothers.<sup>196</sup>

<sup>192.</sup> *Likutei Sichot*, vol. 15, pp. 53-54. <sup>193.</sup> *Likutei Sichot*, vol. 35, pp. 31-38. <sup>194.</sup> Above, 8:1. <sup>195.</sup> *Likutei Sichot*, vol. 30, pp. 31-35. <sup>196.</sup> Rashi on v. 25, below.

— ONKELOS —

19 תלֵהָא אַלִין בְּנֵי נֹחַ וּמֹאֲלִין אַתְּבִדְרוּ כָּל אַרְעָא: 20 וְשָׂרֵי נֹחַ גָּבַר פִּלְחָא בְּאַרְעָא וּנְצִיב בְּרַמָּא: 21 וְשָׂתֵי מִן חֲמָרָא וְרוּי וְאַתְגַּלִּי בְּגוּ מִשְׁכַּנְהּ: 22 וְחֹזָא חָם אָבוּהִי דְכַנְעֵן יֵת עָרִיתָא דְאַבוּהִי וְחֹזִי לְתַרִין אַחוּהִי בְּשׁוּקָא: 23 וְנִסִּיב שָׁם וְיַפֶּת יֵת כְּסוּתָא וְשׁוּיָא עַל כְּתָף תְּרוּיָהוֹן וְאַנְלוּ מְחֻרִין וְכִסִּיאוּ יֵת עָרִיתָא דְאַבוּהוֹן וְאַפִּיָהוֹן מְחֻרִין וְעָרִיתָא דְאַבוּהוֹן לֹא חֹזִי:

19 שְׁלֹשָׁה אֲלֵה בְנֵי־נֹחַ וּמֵאֲלֵה נִפְצָה כָּל־הָאָרֶץ:  
20 וַיַּחַל נֹחַ אִישׁ הָאָדָמָה וַיִּטַּע כַּרְם: 21 וַיִּשְׂתֶּה מִן־הַיַּיִן וַיִּשְׁכַּר וַיִּתְגַּל בְּתוֹךְ אֹהֱלָה: 22 וַיֵּרָא חָם אָבִי כַנְעַן אֶת עֵרוֹת אָבִיו וַיַּגִּד לְשָׁנֵי־אָחִיו בְּחֵיוָן: 23 וַיִּקַּח שָׁם וַיִּפֹּת אֶת־הַשְּׂמֹלֶה וַיִּשְׂימוּ עַל־שִׁכְמָם שְׂנֵיהֶם וַיֵּלְכוּ אַחֲרָיִת וַיִּכְסּוּ אֶת עֵרוֹת אָבִיהֶם וּפְנֵיהֶם אַחֲרָיִת וְעֵרוֹת אָבִיהֶם לֹא רָאוּ:

— RASHI —

וַיִּפֹּת. אֵין כְּתִיב בְּאֵן "וַיִּקַּח" אֶלָּא "וַיִּקַּח", לְמַד עַל שֶׁם שְׂנֵי־אֲמִיץ בַּמִּצְוָה יוֹתֵר מִיַּפֶּת, לְכַף וְכוּ בְּנֵי לְטִלִּית שֶׁל צִיּוּת. וַיִּפֹּת זָכָה לְקַבּוּרָה לְבָנָיו, שְׁנֵי־אֲמִיץ: "אֶתֵּן לְגוֹג מְקוֹם שֶׁם קָבַר". וְחָם שִׁבְּזָה אֶת אָבִיו, נֶאֱמַר בְּרַעֲיוֹ: "כֵּן יִנְהַג מֶלֶךְ אֲשׁוּר אֶת שְׂבִי מִצְרַיִם וְאֵת גְּלוֹת כּוּשׁ נְעָרִים וְזָקְנִים עָרוֹם וְיַחַף וְחֹשׁוֹפֵי שֵׁת" וְגו': וּפְנֵיהֶם אַחֲרָיִת. לָמָּה נֶאֱמַר פֶּעַם שְׁנֵי־? מִלְּמַד, שֶׁכְּשֶׁקְּרָבוּ אֶצְלוֹ וְהִצְרִיכוּ לְהַפּוֹף עֵצְמָם לְכִסּוֹתוֹ הִפְכוּ פְּנֵיהֶם אַחֲרָיִת:

20 וַיַּחַל. עֲשֵׂה עֲצֻמוֹ חֲלִין, שֶׁהָיָה לוֹ לַעֲסֹק תַּחֲלָה בְּנִטְיָעָה אַחֲרֵת: אִישׁ הָאָדָמָה. אֲדוּנֵי הָאָדָמָה, כְּמוֹ: "אִישׁ נְעָמִי": וַיִּטַּע כַּרְם. כְּשֶׁנִּכְנַס לְתַבָּה הַכְּנִיס עִמוֹ וּמֹרוֹת וַיַּחֲרִי תְּאֵנִים: 21 אֹהֱלָה. "אֹהֱלָה" כְּתִיב, רָמַז לַעֲשֵׂרֵת הַשְּׂבָטִים שֶׁנִּקְרְאוּ עַל שֶׁם שׁוּמְרוֹן שֶׁנִּקְרְאָת "אֹהֱלָה", שֶׁגָּלוּ עַל עַסְקֵי הַיַּיִן, שְׁנֵי־אֲמִיץ: "הַשְּׂתִיִּם בְּמִזְרְקֵי יַיִן": וַיִּתְגַּל. לְשׁוֹן "וַיִּתְפַּעַל": 22 וַיֵּרָא חָם אָבִי כַנְעַן. יֵשׁ מְרַבּוֹתֵינוּ<sup>51</sup> אוֹמְרִים: כַּנְעַן רָאָה וְהִגִּיד לְאָבִיו, לְכַף הַזָּכָר עַל הַדְּבָר וְנִתְקַלַּל: וַיֵּרָא אֶת עֵרוֹת אָבִיו. יֵשׁ אוֹמְרִים: סָרְסוּ, וַיֵּשׁ אוֹמְרִים: רַבְעִי<sup>52</sup>: 23 וַיִּקַּח שָׁם

49. רות א, ג. 50. עמוס ו, ו. 51. תנחומא נח, טו. 52. סנהדרין ע, א. 53. יחזקאל לט, יא. 54. ישעיה כ, ד.

— CHASIDIC INSIGHTS —

**23 They did not see their father's nakedness:** If, indeed, they walked in backwards, as the verse explicitly tells us, isn't it obvious that they did not see their father's nakedness?

The import of these words is twofold: in addition to not seeing their father's physical nakedness, Shem and Japheth did not focus on their father's shameful behavior, but focused instead only on what they had to do to correct the situation. Ham, in contrast, "saw his father's nakedness." Not only did he did not remedy the situation; he focused on his father's shortcoming and even told his brothers about it.

Why the dissimilar reactions among the brothers?

The face of another person, says the Ba'al Shem Tov, is like a mirror. If we see evil in another, we are really seeing a reflection of our own evil.<sup>206</sup> Shem and Japheth did not share Noah's weakness for drunkenness; therefore, they did not focus on this shortcoming of their father's. Ham, on the other hand, whose name

connotes hot-bloodedness, *did* share Noah's weakness; therefore he saw and focused on his father's shame.

This teaches us that when we notice shortcomings in someone else, we must also take note of how we react to them. If we take immediate steps to remedy his shortcomings, we can be assured that this is why God arranged for us to notice them in the first place. But if we find ourselves focusing in depth on the other's shortcomings, beyond what is required to correct the situation, then it is clear we are doing so only because we share exactly the same flaw. Since we are generally blind to our own faults, God arranges for us to notice them in someone else, expecting us to take the cue and recognize that we possess these same faults, as well.

Thus, whenever we see or hear about something negative in our fellow, we should try to correct the situation while simultaneously "walking backwards," doing all we can to refrain from seeing and focusing on our fellow's shame.<sup>207</sup>

206. *Meor Einaim*, beginning of parashat Chukat. 207. *Likutei Sichot*, vol. 10, pp. 24-29.

**19 These three were the sons of Noah, and from them the whole world branched out.**

**20 Noah was the master of the soil,**<sup>201</sup> and understood the importance of grain as the mainstay of civilized life. Nonetheless, when he came out of the ark, instead of first planting a grain crop, **he degraded himself by planting a vineyard,** to produce wine for purposes of enjoyment. He had brought vine branches along with him into the ark.<sup>202</sup>

**21 He drank some of the wine and became drunk, and uncovered himself inside his tent.**

**22 Ham's youngest son, Canaan, saw his grandfather exposed.** He ran to tell his father. **Ham, the father of Canaan,** came and entered Noah's tent and **saw his father's nakedness.** He realized that this was his chance to prevent his father from having more children. He first had relations with him and then castrated him, **and then told it to his two brothers outside.**

**23 Shem, enlisting Japheth's help, took a garment and placed it on the shoulders of them both. They then walked into the tent backwards and covered their father's nakedness.** Even when they approached him and had to turn their bodies around, they did so **while facing away from him, so that they did not ever see their father's nakedness.**

#### ✿ INNER DIMENSIONS ✿

**[21] He drank some of the wine and became drunk:** The *Zohar* notes that while "Eve entered the world and became attached to the snake... and Noah entered the world...drank from the wine, and became drunk... Sarah descended [to Egypt] and went up unscathed."

A fundamental concept in Judaism is the importance of serving God with joy. The renowned kabbalist, Rabbi Yitzchak Luria (the *Arizal*), when asked by his students why he had merited Divine inspiration and encounters with the prophet Elijah, replied that it was only by virtue of performing the commandments with intense joy. Performing the commandments joylessly is lacking and incomplete, and therefore cannot bring the world to perfection.

According to the Midrash, the forbidden fruit Eve offered Adam was wine; Eve was aware of the importance of joy and sought to attain it through wine. But she failed to experience *holy* joy, since she succumbed to the feelings of self-awareness and ego that are the by-products of less-than-holy celebrating. Prior to the sin, Adam and Eve were merely a vehicle for Divine expression; once they took the fateful sip of wine, they gained self-awareness and began to operate in a realm of seeming separateness from God.

Noah attempted to rectify Eve's error, to experience joy without self-awareness. He therefore sought to

negate his selfhood through drunkenness. But this endeavor was misguided, since the goal is not to numb the mind and emotions through drinking, but rather to lose the self through humility and surrender to God.

Selfless joy was finally achieved by Sarah, who is associated with *malchut* (the name *Sarah* is derived from the word *serarah*, "rulership"). *Malchut*, the lowest *sefirah*, has no intrinsic "content" of its own, and receives whatever it has from the higher *sefirot*. This is the epitome of selflessness. True joy is born of humility, since one who is humble does not feel deserving of anything and is therefore never disappointed. Joy born of selflessness has no negative consequences; on the contrary, it brings us to the highest levels of spiritual experience, a taste of the World to Come. This is why Sarah's son was named *Yitzchak* ("laughter"), a foretaste of the messianic era, when "our mouths will be filled with laughter."<sup>203</sup> This is why King David, who also embodies *malchut* and selflessness, also epitomized serving God with joy.<sup>204</sup> Similarly, Rabbi Yitzchak Luria was a spark of the soul of Moses, the humblest of all men, and therefore experienced true joy.

We, too, when we emulate the humility of Sarah, Moses, King David, and Rabbi Luria, can fulfill our Divine mission with true joy and without fear of negative repercussions.<sup>205</sup>

201. See 5:21, above. 202. See 7:13, above. 203. Psalms 126:2. 204. See *Mishneh Torah*, *Lulav* 8:15; 2 Samuel 6:16. 205. *Sefer HaMa'amaram Melukat*, vol. 2, pp. 148-153; *Ma'amarei Admur HaZaken* 5562, vol. 1, p. 51.

— ONKELOS —

24 וְאֶתְעַר נֹחַ מִחֲמֵרָה וַיִּדַע יֵת  
דִּי עֵבֶד לֵה בְרָה זְעִירָא: 25 וְאָמַר  
לִיט כְּנָעַן עֶבֶד פְּלַח עֶבְדִּין וְהִי  
לְאַחֹהָ: 26 וְאָמַר בְּרִיךְ יְיָ אֱלֹהֵהָ  
דְּשֵׁם וַיְהִי כְּנָעַן עֶבְדָּא לְהוּן:  
27 וַפְתִּי יְיָ לִפְתַּי וַיִּשְׂרִי שְׂכִינְתָהָ  
בְּמִשְׁכְּנֵי שָׁם וַיְהִי כְּנָעַן עֶבְדָּא  
לְהוּן: 28 וַחֲזִיא נֹחַ בְּתֵר טוֹפְנָא  
תְּלַת מָאָה וַחֲמִשִּׁין שָׁנִין: 29 וַהֲוֹ  
כֹּל יוֹמֵי נֹחַ תִּשְׁעָה מָאָה וַחֲמִשִּׁין  
שָׁנִין וּמִיַּת: 101 וְאֵלֶּיךָ תוֹלְדֵת  
בְּנֵי נֹחַ שֵׁם חָם וַיִּפְתַּי וַאֲתִילִידוּ  
לְהוּן בְּנֵין בְּתֵר טוֹפְנָא: 2 בְּנֵי יֶפֶת  
גָּמַר וּמִגּוֹג וּמְדֵי וַיְוֹן וְתוֹבֵל וּמְשַׁךְ  
וְתִירָס:

24 וַיִּקְרַן נֹחַ מֵיִינוּ וַיִּדַע אֶת אֲשֶׁר-עָשָׂה לוֹ בְּנוֹ הַקָּטָן:  
25 וַיֹּאמֶר אָרוּר כְּנָעַן עֶבֶד עֲבָדִים יִהְיֶה לְאַחִיו:  
26 וַיֹּאמֶר בְּרוּךְ יְהוָה אֱלֹהֵי שָׁם וַיְהִי כְנָעַן עֶבֶד לְמוֹ:  
27 יֶפֶת אֱלֹהִים לִיֶּפֶת וַיִּשְׁכֵּן בְּאַהֲלֵי-שָׁם וַיְהִי כְנָעַן  
עֶבֶד לְמוֹ: 28 וַיְחִי-נֹחַ אַחֲרֵי הַמַּבּוּל שְׁלֹשׁ מֵאוֹת שָׁנָה  
וַחֲמִשִּׁים שָׁנָה: 29 וַיְהִי כָל-יְמֵי-נֹחַ תִּשְׁעָה מֵאוֹת שָׁנָה  
וַחֲמִשִּׁים שָׁנָה וַיָּמָת: פ

10:1 וְאֵלֶּה תוֹלְדֵת בְּנֵי-נֹחַ שֵׁם חָם וַיִּפְתַּי וַיִּוֹלְדוּ לָהֶם  
בָּנִים אַחֲרֵי הַמַּבּוּל: 2 בְּנֵי יֶפֶת גָּמַר וּמִגּוֹג וּמְדֵי וַיְוֹן וְתוֹבֵל  
וּמְשַׁךְ וְתִירָס:

— RASHI —

שְׁעִתִּיד לְשִׁמּוֹר הַבְּטָחָה לְזָרְעוֹ, לְתַת לָהֶם אֶת אֶרֶץ  
כְּנָעַן: וַיְהִי. לָהֶם כְּנָעַן לְמִסַּע עוֹבֵד: 27 יֶפֶת אֱלֹהִים  
לִיֶּפֶת. מִתְרַגֵּם "יֶפֶתִי", יְרַחֵב: וַיִּשְׁכֵּן בְּאַהֲלֵי שָׁם. יִשְׂרָה  
שְׂכִינְתוֹ בְּיִשְׂרָאֵל. וּמְדַרְשׁ חֲכָמִים<sup>56</sup>: אִף עַל פִּי שְׂפֵת  
אֱלֹהִים לִיֶּפֶת, שֶׁבְנָה כְרֶשֶׁת שְׂהִיָּה מִבְּנֵי יֶפֶת בֵּית שְׁנֵי, לֹא  
שְׂרָתָה בּוֹ שְׂכִינָה, וְהִיכֵן שְׂרָתָה? בְּמִקְדָּשׁ רֵאשׁוֹן שֶׁבְנָה  
שְׁלֹמֹה, שְׂהִיָּה מִבְּנֵי שָׁם: וַיְהִי כְנָעַן עֶבֶד. אִף מְשִׁיגְלוֹ בְּנֵי  
שָׁם, וּמְכָרוּ לָהֶם עֲבָדִים מִבְּנֵי כְנָעַן: 2 וְתִירָס. זוֹ פְּרִס:

24 בְּנוֹ הַקָּטָן. הַפְּסוּל וְהַבְּזוּי, כְּמוֹ<sup>55</sup>: "הִנֵּה קָטָן נִתְתִּיר  
בְּגוּיִם בְּזוּי בְּאָדָם": 25 אָרוּר כְּנָעַן. אֵתָה גְרַמְתָּ לִּי  
שְׂלֵא אוֹלִיד בֶּן רְבִיעִי אַחֲרֵי לְשִׁמְשֻׁנִי, אָרוּר בְּנֵךְ רְבִיעִי  
לְהִיֹּת מְשֻׁמֵּשׁ אֶת זְרַעֲם שֶׁל אֱלוֹ הַגְּדוֹלִים, שְׂהוּטֵל  
עֲלֵיהֶם טוֹרַח עֲבוּדָתִי מֵעַתָּה. וּמָה רָאָה חָם שֶׁסְּרָסוּ?  
אָמַר לָהֶם לְאַחִיו: אָדָם הָרֵאשׁוֹן שְׁנֵי בָנִים הָיוּ לוֹ, וְהָרַג  
זֶה אֶת זֶה בְּשִׁבִיל יְרֵשֶׁת הָעוֹלָם, וְאָבִינוּ יֵשׁ לוֹ שְׁלֹשָׁה  
בָּנִים, וְעוֹדְנוּ מְבַקֵּשׁ בֶּן רְבִיעִי: 26 בְּרוּךְ ה' אֱלֹהֵי שָׁם.

55. ירמיה מט, טו. 56. יומא י, א. 57. יונה ג, ג. 58. לקמן יא, י. 59. פרק א. 60. להלן פסוק כו. 61. להלן

## 2 The sons of Japheth were Gomer, Magog, Madai, Yavan, Tuval, Meshech, and Tiras, who later became known as Persia.

— CHASIDIC INSIGHTS —

**26 The Court of Death:** The Midrash explains that the people of "the Court of Death" were ascetics who ate very simple foods, dressed in simple clothing, and awaited death every day.<sup>215</sup> Although this was before the Dispersion and physical pleasures abounded, these people preferred not to be steeped in the physicality of this world. On the contrary, they were anxious to move on to a more spiritual existence and be free of the limitations and desires the accompany materiality. This was therefore a place free of jealousy and of the pursuit of pleasure.

How, indeed, were they able to resist the abundance of worldly pleasures? The answer is that Chatzarmavet was the child of Yoktan (the "Small One"), so named because of his humility. A humble person is capable of remaining above the hedonism that others fall into.

We, too, should learn from this father-and-son pair. Our society places great emphasis on ostentation and prodigality: this emphasis is so pervasive that we are willing to go into debt to capitulate. Then we claim that we have no money to give to charity, which is unfortunately actually true since we are living off borrowed money! Our ostentation traps us in a vicious circle: as soon as others see our conspicuous consumption, they feel compelled to outdo us.

We should rather strive, like Chatzarmavet, to rise above the material distractions of this world and neither bury ourselves in the luxury of gourmet food and fancy clothing nor succumb to envy. But in order to raise such children, we must, like Yoktan, strive to be humble and selfless ourselves.<sup>216</sup>

215. Bereishit Rabbah 37:8. 216. Likutei Sichot, vol. 5, pp. 286-288.

**24 Noah awoke from his wine and realized what his youngest, immature, and degenerate son had done to him.**

**25 He said, “Cursed be Canaan!** Because of you, Ham, I will never have a fourth son to tend to me, and I no longer want *you* to tend to me. Therefore, since my eldest sons will now have this responsibility, I decree that *your* fourth son **shall be a slave’s slave**—a slave to his father’s brothers, Shem and Japheth, who must now serve me alone!”

**26 He then said, “Blessed be God, the God** who will favor **Shem** by giving his descendants the Promised Land! **Canaan’s** descendants **shall be their slaves** and pay them tribute!

**27 May God expand Japheth** materially, **but may He dwell in the tents of the descendants of Shem.** (One fulfillment of this prophecy occurred with regard to the two Temples in Jerusalem: The first Temple, built by Solomon, a descendant of Shem, was endowed with a far greater measure<sup>208</sup> of Divine revelation than was the second Temple, which was built by Cyrus the Persian, a descendant of Japheth.<sup>209</sup>) **And let Canaan’s** descendants **be slaves** to the descendants of Shem even when the latter will dwell in countries other than their own!”

In addition to Noah’s explicit prophecies, there were additional repercussions to each son’s behavior in this incident. Shem, for having cloaked his father, earned the privilege that his descendants (the Jewish people) would wear the ritual prayer blanket (*talit*).<sup>210</sup> Japheth, for having assisted his brother Shem in covering their father, earned the privilege that his eschatological descendant (Gog) would be buried in the Land of Israel.<sup>211</sup> Ham, for having capitalized on his father’s exposure, earned the degrading embarrassment that his descendants would be carried off naked into captivity.<sup>212</sup>

## The Seventy Nations

**28** Having concluded the narrative of Noah, the Torah now details the genealogy of his descendants.

**Noah lived 350 years after the Flood,** which occurred in the 600<sup>th</sup> year of his life.

**29 All the days of Noah thus came to 950 years, and he died.**

**10:1 The following are the descendants of Noah’s sons, Shem, Ham, and Japheth, who fathered children after the Flood.** The generations after the Flood learned the main lesson of the Flood—that wanton abuse of the limits God imposes on human procreative activity brings wanton destruction, as does robbery—and they therefore undertook to refrain from committing these sins. However, they *did* continue to worship idols; the vast majority of the nations listed here were idolaters.

In accordance with God’s instructions that his descendants fill the world,<sup>213</sup> Noah divided up the known world, assigning a specific geographical region to each of his seventy descendants. In accordance, again, with God’s original intention, he assigned the Land of Israel to the descendants of Shem.<sup>214</sup>

<sup>208.</sup> *Likutei Sichot*, vol. 11, p. 176, note 8. <sup>209.</sup> Below, 10:2. *Likutei Sichot*, vol. 5, p. 284. <sup>210.</sup> See on Exodus 33:20, Numbers 15:37-41. <sup>211.</sup> Ezekiel 39:11. <sup>212.</sup> Isaiah 20:4. <sup>213.</sup> 9:1, above. <sup>214.</sup> Rashi on 12:6, below; *Likutei Sichot*, vol. 5, p. 11.

— ONKELOS —  
 3 ובני גמר אשכנז ורפת ותוגרמה:  
 4 ובני יון אלישה ותרשיש כתיים  
 ודודנים: 5 מאלין אתפרשו נגות  
 עממיא בארעתהון גבר ללשנה  
 לורעתהון בעממיהון: 6 ובני חם  
 כוש ומצרים ופוט וכנען: 7 ובני  
 כוש סבא וחילא וסבתה ורעמה  
 וסבתא ובני רעמה שבא ודדן:  
 8 וכוש אוליד ית נמרוד הוא שרי  
 למיהוי גבר תקיף בארעא: 9 הוא  
 היה גבר תקיף קדם יי על פן  
 יתאמר בנמרוד גבר תקיף קדם  
 ה'.

3 ובני גמר אשכנז ורפת ותוגרמה: 4 ובני יון אלישה  
 ותרשיש כתיים ודודנים: 5 מאלה נפרדו איי הגוים  
 בארצתם איש ללשנו למשפתתם בגויהם: 6 ובני חם  
 כוש ומצרים ופוט וכנען: 7 ובני כוש סבא וחילא וסבתה  
 ורעמה וסבתא ובני רעמה שבא ודדן: 8 וכוש ילד את  
 נמרוד הוא החל להיות גבר בארץ: 9 הוא היה גבר ציד  
 לפני יהוה על כן יאמר בנמרוד גבור ציד לפני יהוה:

— RASHI —

להקניטו על פניו: על פן יאמר. על כל אדם מרשיע  
 בעזות פנים, יודע רבונו ומתפון למרוד בו, יאמר: זה  
 "בנמרוד גבור ציד":

8 להיות גבר. להמריד כל העולם על הקדוש ברוך  
 הוא, בעצת דור הפלגה: 9 גבור ציד. צד דעתן של  
 בריות בפיו, ומטען למרוד במקום: לפני ה'. מתפון

— CHASIDIC INSIGHTS —

If we make our devotion to the Torah and religious life  
 our highest priority, and express this by aggrandizing  
 our religious institutions, not only will our "city" — our

civilization — prosper, our enemies will be transformed  
 into allies. In addition, we will perpetuate our names  
 eternally in the annals of Judaism and justice.<sup>223</sup>

— INNER DIMENSIONS —

**[4] Let us make ourselves a name:** The Generation  
 of the Dispersion wished to receive sustenance  
 from on High without curbing their egos and  
 desires. Their plan was to elicit sustenance from the  
 Name *Havayah*, although they deserved no better  
 than to receive sustenance from the lowest levels  
 of the Name *Elokim*. They desired to reach beyond  
 the law-and-order world of *Tikun* to the world of  
*Akudim*, where the structure of *Tikun* does not exist.  
 This verse can thus be interpreted as follows:

*Let us make ourselves a name:* "Let us draw from the  
 Name *Havayah*."

*so that we will not be scattered:* "lest we receive from  
 the lowest levels of the Name *Elokim*."

To achieve this unity, they planned to build a tower.

As the medieval commentator, Rabbi Avraham  
 Ibn Ezra explains, they were shepherds who often  
 roamed far from one another. This tall tower would  
 be visible to them all from afar, so they would  
 be able to return to it to regroup and reunite.

God therefore could not allow their plan to succeed,  
 since through unity they indeed would have been  
 able to elicit Divine beneficence from the Name  
*Havayah* and channel it into impurity. (Similarly,  
 once Adam had internalized evil by eating from the  
 Tree of Knowledge, God did not want him to eat  
 from the Tree of Life and gain immortality, thereby  
 eternalizing evil.)<sup>224</sup>

The sin of this generation caused the Divine Presence  
 to retreat from the fourth firmament to the fifth.<sup>225</sup>

— A CLOSER LOOK —

**[9] God dispersed them and revoked their  
 privilege of entry into the after life:** Although  
 their punishment in *this* world was less severe than  
 that received by the Generation of the Flood, their  
 punishment in the *next* world was more severe.<sup>226</sup>  
 This is because the Generation of the Dispersion  
 sinned against God, not against their fellow,  
 whom they treated with love and friendship. Their

punishment is therefore accordingly spiri tual, to be  
 meted out in the next world.

In contrast, the Generation of the Flood sinned  
 against their fellow: they stole from each other<sup>227</sup>  
 and fought constantly, thus disrupting the peaceful  
 order that God intended for this world. They were  
 therefore punished in this world. Nevertheless, at  
 least according to one opinion, they *do* have a share

223. *Likutei Sichot*, vol. 3, pp. 751-753. 224. *Torah Or* 11b. 225. *Torah Or* 11b. 226. *Shir HaShirim Rabbah* 5:1; *Sefer HaMa'amarim* 5710,  
 pp. 111 ff. 227. See *Sanhedrin* 108a.

**3 The sons of Gomer were Ashkenaz, Rifat, and Togarmah.**

**4 The sons of Yavan were Elishah, Tarshish, the Kittites, and the Dodanites.**

**5 From these, the island-nations, their clans, and their nations branched out, each with its language, into their lands.**

**6 The sons of Ham were Kush, Egypt, Put, and Canaan.**

**7 The sons of Kush were Seva, Chavilah, Savtah, Ra'amah, and Savtecha. The sons of Ra'amah were Sheva and Dedan.**

**8 Kush was the father of Nimrod ["Let us rebel"], the first man in the world powerful enough to rally the masses to rebel against God, as will be described below.<sup>217</sup>**

**9 He was a mighty hunter, "trapping" people by convincing them to join his rebellion against God, and he flaunted his rebellious intentions before GOD Himself. Hence, the saying, "He is like Nimrod, a mighty hunter before GOD" is applied to anyone who intentionally seeks to provoke God's anger.**

---

✧ CHASIDIC INSIGHTS ✧

---

**4 Let us make ourselves a name:** The incident of the Tower of Babel occurred in the aftermath of the Flood. The survivors sought to ensure their self-preservation and protect themselves from destruction, but overlooked the Flood's lesson that we must look to God to ensure our well-being.

Today, the Jewish people are also living in the aftermath of a "flood" that killed millions of Jews. We, the survivors, must be careful not to make the same mistake as the survivors of Noah's flood.

Although building the infrastructure of civilization, and certainly that of Jewish civilization, is a praiseworthy cause, it cannot be an end in itself. Nothing is shallower than simple self-preservation, historical self-perpetuation, and the endless drive to enhance

our standard of living.<sup>218</sup> Moreover, if these are our sole aspirations in life, it is a small step from there to believing that the end justifies the means, and we can eventually find ourselves justifying all sorts of unethical behavior to achieve our ends.

In order for our "city and tower" to endure, it must possess a deeper, Godly purpose. We should therefore respond to the "flood" by constructing a holy and Godly "city and tower," which means that our religious institutions—our houses of prayer and Torah study—should be the most cherished and well-maintained institutions of our society, and should be housed in the most prominent buildings in our cities.<sup>219</sup> They are the true "tower" of the city, which will protect us both from external and internal adversity.

✧ INNER DIMENSIONS ✧

**[3] Let us mold bricks:** The souls of the Generation of the Dispersion were rooted in an extremely lofty spiritual level. However, when they descended into the physical world, they fell into depravity. Because they sinned with brick and mortar, they had to be purified of this sin through labor that involved brick and mortar. They were therefore reincarnated as the Jews who were enslaved in Egypt. This is the deeper meaning of Pharaoh's statement: "You must impose upon them the same quota of bricks as they made until now,"<sup>220</sup> i.e., they must produce the identical quantity of bricks now as they made during their attempt to build the tower in their previous incarnation. This is also the deeper answer to Moses' question: "What sin have the Jews committed for

which they have been singled out from among all nations to suffer such backbreaking labor?"<sup>221</sup> Moses did not know that it was not their sin, but rather the sin of their previous incarnation, from which they needed to be purified in order to receive the Torah. Once their souls had been purified, they reverted to their original lofty stature. They were then fit to receive the Torah, through which their arduous labor of creating physical mortar (*chomer*) and bricks (*levainah*) was replaced with the intellectual labor of deriving new laws through *a fortiori* reasoning (*kal vachomer*) and refining their understanding of Torah law until they reached authoritative legal decisions (*libun hilchata*).<sup>222</sup>

---

<sup>217</sup> 11:1-9. <sup>218</sup> See *Moreh Nevuchim* 3:13. <sup>219</sup> See *Shabbat* 11a; *Shulchan Aruch, Orach Chaim* 150:2. <sup>220</sup> Exodus 5:8. <sup>221</sup> Rashi on Exodus 2:14. <sup>222</sup> See on Exodus 1:14; *Sefer HaMa'amarim* 5226, pp. 117, 316; *Pri Etz Chaim, Sha'ar Chag HaMatzot*.

ONKELOS

10 וְהָיָה רִישׁ מַלְכוּתָהּ בְּכָל  
 וְאָרְךָ וְאָכַד וְכַלְנֵה בְּאֶרְעָא  
 דְּבַבְלָא: 11 מִן אֶרְעָא הֵיכִיא נֶפֶק  
 אֲתוּרָאָה וּבְנָא יֵת גִּינְוָה וְיֵת  
 רְחוּבוֹת קֶרְתָּא וְיֵת כְּלָח: 12 וְיֵת  
 רֶסֶן בֵּין גִּינְוָה וּבֵין כְּלָח הֵיא  
 קֶרְתָּא רַבְתָּא: 13 וּמִצְרַיִם אוֹלִיד  
 יֵת לוֹדָאֵי וְיֵת עֲנַמְאֵי וְיֵת לְהַבְּאֵי  
 וְיֵת נַפְתוּחָאֵי: 14 וְיֵת פְּתוּסָאֵי  
 וְיֵת כְּסוּלּוּחָאֵי דִּי נֶפְקוּ מִתְּמִן  
 פְּלִשְׁתֵּי וְיֵת קְפוּטָאֵי: 15 וּכְנַעַן  
 אוֹלִיד יֵת צִידוֹן בְּכַרְה וְיֵת חַת:  
 16 וְיֵת יְבוּסָאֵי וְיֵת אַמּוֹרָאֵי וְיֵת  
 גְּרָגְשָׁאֵי: 17 וְיֵת חוּאֵי וְיֵת עֶרְקָאֵי  
 וְיֵת אֲנַתוּסָאֵי: 18 וְיֵת אֲרוּדָאֵי  
 וְיֵת צְמָרָאֵי וְיֵת חֲמַתָּאֵי וּבְתַר כֵּן  
 אֲתַבְּדוּ וְרַעֲיַת כְּנַעֲנָאֵי: 19 וְהָיָה  
 תַּחֲסוּם כְּנַעֲנָה מִצִּידוֹן מְטִי לְגַרְר  
 עַד עֵזָה מְטִי לְסָדוּם וְעַמּוֹנָה  
 וְאֲדָמָה וְצַבּוּזִים עַד לְשַׁע: 20 אֲלִין  
 בְּנֵי חָם לְרַעֲיַתְהוֹן לְלִשְׁנֵיהוֹן  
 בְּאֶרְעֵתְהוֹן בְּעַמְמֵיהוֹן: 21 וְלִשְׁם  
 אֲתִילִיד אֶף הוּא אָבוּהוֹן דְּכָל בְּנֵי  
 עֶבֶר אַחוּהֵי דִּפְת רַבָּא: 22 בְּנֵי  
 שֵׁם עֵילָם וְאַשּׁוּר וְאַרְפַּכְשָׁד  
 וְלוֹד וְאַרְם: 23 וּבְנֵי אַרְם עוּץ  
 וְחוּל וְגֵתֵר וְמִשׁ: 24 וְאַרְפַּכְשָׁד  
 אוֹלִיד יֵת שְׁלַח וְשְׁלַח אוֹלִיד יֵת  
 עֶבֶר: 25 וְלַעֲבָר אֲתִילִידוּ תְרִין  
 בְּנֵי שׁוּם חַד פְּלֶג אַרִי בְּיוֹמוּהֵי  
 אֲתַפְּלִגַּת אֶרְעָא וְשׁוּם אַחוּהֵי  
 יִקְטָן:

10 וְהָיָה רִאשִׁית מַמְלַכְתּוֹ בְּכָל  
 וְאָרְךָ וְאָכַד וְכַלְנֵה  
 בְּאֶרְצֵי שֹׁנַעַר: 11 מִן־הָאָרֶץ  
 הַזֹּאת יֵצֵא אֲשׁוּר וַיִּבְנֶן אֶת־  
 נִינְוֵה וְאֶת־רְחֹבֹת עִיר וְאֶת־כְּלָח: 12  
 וְאֶת־רֶסֶן בֵּין נִינְוֵה  
 וּבֵין כְּלָח הוּא הָעִיר הַגְּדוֹלָה: 13  
 וּמִצְרַיִם יָלַד אֶת־לוּדִים  
 וְאֶת־עֲנַמִּים וְאֶת־לְהָבִים  
 וְאֶת־נַפְתָּחִים: 14 וְאֶת־  
 פְּתֻרְסִים וְאֶת־כְּסוּלּוּחִים  
 אֲשֶׁר יֵצְאוּ מִשָּׁם פְּלִשְׁתִּים  
 וְאֶת־כְּפֻתָרִים: 15

15 וּכְנַעַן יָלַד אֶת־צִידוֹן  
 בְּכָרוֹ וְאֶת־חַת: 16 וְאֶת־הַיְבוּסִי  
 וְאֶת־הָאֲמּוֹרִי וְאֶת  
 הַגְּרָגְשִׁי: 17 וְאֶת־הַחוּי  
 וְאֶת־הָעֶרְקִי וְאֶת־הַסִּינִי:  
 18 וְאֶת־הָאֲרוּדִי וְאֶת־הַצְּמָרִי  
 וְאֶת־הַחֲמַתִּי וְאַחַר  
 נִפְעוּ מִשְׁפָּחוֹת הַכְּנַעֲנִי:  
 19 וַיְהִי גְבוּל הַכְּנַעֲנִי  
 מִצִּידוֹן בְּאַכָּה  
 גְּרָרָה עַד־עֵזָה בְּאֲכָה  
 סָדוּמָה וְעַמּוֹנָה  
 וְאֲדָמָה וְצַבּוּזִים  
 עַד־לְשַׁע: 20 אֱלֹהֵי  
 בְנֵיהֶם לְמִשְׁפָּחָתָם  
 לְלִשְׁנָתָם בְּאֶרְצָתָם  
 בְּגוּיָהֶם: 21

21 וְלִשְׁם יָלַד גַּם־הוּא  
 אָבִי כָל־בְּנֵי־עֶבֶר  
 אַחִי יִפְתַּח הַגְּדוֹל:  
 22 בְּנֵי שֵׁם עֵילָם  
 וְאַשּׁוּר וְאַרְפַּכְשָׁד  
 וְלוֹד וְאַרְם: 23  
 וּבְנֵי אַרְם עוּץ וְחוּל  
 וְגֵתֵר וְמִשׁ: 24 וְאַרְפַּכְשָׁד  
 יָלַד אֶת־שְׁלַח וְשְׁלַח  
 יָלַד אֶת־עֶבֶר: 25 וְלַעֲבָר  
 יָלַד שְׁנֵי בָנִים  
 שֵׁם הָאֶחָד פְּלֶג כִּי  
 בְּיָמָיו נִפְלְגָה הָאָרֶץ  
 וְשֵׁם אַחִיו יִקְטָן:

RASHI

אחר המבול, והיו אומר יפת הגדול, שהרי בן חמש מאות שנה היה נח כשהתחיל להוליד, והמבול היה בשנת שש מאות שנה, נמצא שהגדול בבניו היה בן מאה שנה, ושם לא הגיע למאה שנה עד שנתים אחר המבול: אחי יפת, ולא אחי חם, שאלו שניהם כברו את אביהם, וזה בזה: 25 נפלגה, נתפלגו הלשונות, ונפוצו מן הבקעה, ונתפלגו בכל העולם, למדנו שהיה עבר נביא, שקרא שם בנו על שם העתיד, ושנינו ב"סדר עולם"<sup>59</sup> שבסוף ימיו נתפלגו, שאם תאמר בתחלת ימיו, הרי יקטן אחיו צעיר ממנו והוליד כמה משפחות קדם לכן, שנאמר: "ויקטן ילד" וגו', ואחר כך<sup>60</sup>: "ויהי כל הארץ" וגו'. ואם תאמר באמצע ימיו, לא בא הכתוב לסתום אלא לפרש. הא למדת, שבשנת מות פלג נתפלגו: ויקטן, שהיה ענו ומקטין עצמו, לכך זכה להעמיד כל המשפחות הללו:

11 מן הארץ. כיון שראה אשור את בניו שומעין לנמרוד ומורדין במקום לבנות המגדל, יצא מתוכם: 12 העיר הגדולה. היא נינוה, שנאמר<sup>61</sup>: "ונינוה היתה עיר גדולה לאלהים": 13 להבים. שפניהם דומים ללהב: 14 ואת פתרסים ואת כסלחים אשר יצאו משם פלשתים. משניהם יצאו, שהיו פתרוסים וכסלוחים מחיפין משכב נשותיהם אלו לאלו, ויצאו מהם פלשתים: 18 ואחר נפצו. מאלה נפצו משפחות הרבה: 19 גבול הכנעני. סוף ארצו. כל "גבול" שבמקרא לשון סוף וקצה: באכה. שם דבר. ולי נראה, כאדם האומר לחברו: גבול זה מגיע עד אשר תבא לגבול פלוני: 20 ללשונתם בארצתם. אף על פי שנתלקו ללשונות וארצות, כלם בני חם הם: 21 אבי כל בני עבר. הנהר היה שם: אחי יפת הגדול. אינו יודע אם יפת הגדול אם שם, כשהוא אומר<sup>62</sup>: "שם בן מאת שנה וגו' שנתים

יא, א.

**10 His kingdom began with Babylon, and with Erech, Akad, and Kalneh, in the land of Shinar.**

**11 But when its inhabitants began to follow Nimrod, Assyria<sup>228</sup> and his family left that land and built Nineveh, Rechovot-Ir and Kalach,**

**12 as well as Resen, between Nineveh and Kalach; Nineveh is the great city, the capital of Assyria.**

**13 Egypt fathered the Ludites, the Anamites, the Lehavites (“Flames,” so known because of their fiery faces), the Naftuchites,**

**14 the Patrusites and the Kasluchites—who engaged in wife-swapping and produced the Philistines, who thus descended from them both—and the Kaftorites.**

**15 Canaan was the father of Sidon, his firstborn, and Het,**

**16 as well as the Jebusites, the Amorites, the Girgashites,**

**17 the Hivites, the Arkites, the Sinites,**

**18 the Arvadites, the Zemarites, and the Hamathites. From these, the families of the Canaanites later spread out further.**

**19 The Canaanite borders extended from Sidon toward Gerar until Gaza, and toward Sodom, Gomorrah, Admah, and Tzevoyim, until Lasha.**

**20 These are the descendants of Ham, according to their clans and languages, by their lands and nations.**

**21 Children were also born to Shem. He was the ancestor of all those who lived on the other, eastern side of the Euphrates, and the brother of Japheth, the eldest son of Noah and the only other son who honored him.**

**22 The sons of Shem were Elam, Assyria, Arpachshad, Lud, and Aram.**

**23 The sons of Aram were Utz, Chul, Geter, and Mash.**

**24 Arpachshad was the father of Shelach, and Shelach was the father of Ever.**

**25 Two sons were born to Ever. The name of the first was Peleg, because his father prophesied that in the final days of his life, the world would be divided [niflegah], as will be described below.<sup>229</sup> The name of his brother was Yoktan (“the Small One,” so named because of his humility).**

#### ☞ A CLOSER LOOK ☞

**[continued...]** in the afterlife, since they did not sin against God.

The truth is that sins against God are also sins against our fellow, since our failure to fulfill the Torah’s precepts prevents God’s beneficence from coming into the world and others from benefiting

from it. Similarly, sins against man are also sins against God, who commanded us to be good to each other. Nevertheless, the clearly “social” sins are more closely related to this world and the clearly “religious” sins are more closely related to the next world.<sup>230</sup>

<sup>228</sup>. Below, v. 22. <sup>229</sup>. 11:1-9. <sup>230</sup>. *Likutei Sichot*, vol. 3, pp. 754-755. See Maimonides’ *Commentary on the Mishnah*, beginning of *Peah*.

ONKELOS

26 וַיִּקְטֹן אוֹלֵיד יְת אֱלֹמוֹדֵד וְיֵת שְׁלֵף וְיֵת חֲצֵרְמוֹת וְיֵת יֵרַח: 27 וְיֵת הַדְּוֹרִים וְיֵת אֵזֶל וְיֵת דְּקָלָה: 28 וְיֵת עֹבֵל וְיֵת אֲבִימָאֵל וְיֵת שָׁבָא: 29 וְיֵת אוֹפִיר וְיֵת חֲוִילָה וְיֵת יוֹבֵב כָּל אֵלִין בְּנֵי יִקְטָן: 30 וְהָיָה מוֹתְבִנְהוֹן מִמֶּשָׂא מְטִי לְסִפְרָ טוֹר מְדִינָהָא: 31 אֵלִין בְּנֵי שָׁם לְיִרְעִיתְהוֹן לְלִשְׁנִיהוֹן בְּאַרְעִיתְהוֹן בְּעַמְמִיהוֹן: 32 אֵלִין וְרַעִית בְּנֵי נֹחַ לְתוֹלְדֵתְהוֹן בְּעַמְמִיהוֹן וּמְאֵלִין אֲתַפְּרְשׁוּ עִמְמִיָּא בְּאַרְעָא בְּתַר טוֹפְנָא:

26 וַיִּקְטֹן יֵלֵד אֶת־אֱלֹמוֹדֵד וְאֶת־שְׁלֵף וְאֶת־חֲצֵרְמוֹת וְאֶת־יֵרַח: 27 וְאֶת־הַדְּוֹרִים וְאֶת־אֵזֶל וְאֶת־דְּקָלָה: 28 וְאֶת־עֹבֵל וְאֶת־אֲבִימָאֵל וְאֶת־שָׁבָא: 29 וְאֶת־אוֹפִיר וְאֶת־חֲוִילָה וְאֶת־יוֹבֵב כָּל־אֵלֶּה בְּנֵי יִקְטָן: 30 וַיְהִי מוֹשְׁבָם מִמֶּשָׂא בְּאֶבֶה סִפְרָה הַר הַקָּדָם: 31 אֵלֶּה בְּנֵי־שָׁם לְמִשְׁפְּחֹתָם לְלִשְׁנֹתָם בְּאַרְצֹתָם לְגוֹיֵהֶם: 32 אֵלֶּה מִשְׁפְּחֹת בְּנֵי־נֹחַ לְתוֹלְדֹתָם בְּגוֹיֵיהֶם וּמְאֵלֶּה נִפְרְדוּ הַגּוֹיִם בְּאַרְצֵי אַחַר הַמַּבּוּל: פ

RASHI

26 חֲצֵרְמוֹת. על שם מקומו. דְּבָרֵי אֲנָדָה<sup>62</sup>:

62. בראשית רבה לו, ח.

CHASIDIC INSIGHTS

ative energies of the world and give them extra vitality until we repent and thereby retrieve those energies.<sup>233</sup>) Abraham, the personification of kindness, tried to draw every person closer to God. He even prayed for the inhabitants of Sodom! Through this work, he retroactively refined the previous generations and therefore received their reward, retrieving the Divine blessings that had been temporarily diverted to the forces of evil.<sup>234</sup> To phrase this in simpler terms: There are two types of evil, each requiring a different response: (a) evil that is *entirely* evil and contains no good, and must therefore

be eradicated; and (b) evil that, although *we* can't see any good in it, does contain a spark of goodness. This type of evil is not meant to be destroyed, but rather transformed into good. The evil of the first set of ten generations was utter, of the sort that destroys the world. God therefore completely wiped out these generations through the Flood. In contrast, the evil of the second ten generations was of the sort that *can* be transformed to good. Abraham was therefore able to rectify and complete the good that was concealed in their deeds and therefore "re-

INNER DIMENSIONS

[30] **She had no child:** This phrase reads literally, "there is not to her a child." The word for "there is not" (אין) can also be read as "nothingness" (אין), which alludes to the *sefirah* of *keter*, since it is above normative consciousness and is therefore "nothing" from our perspective. The verse can thus be read to mean that her future child, Isaac, stemmed from the lofty *sefirah* of *keter*. Because of his lofty origin, this child took a long time to descend into this world, and therefore Sarah underwent a long period of infertility.<sup>235</sup>

[31] **God's anger...had been increasingly intensifying:** Despite this anger, the early generations enjoyed great longevity. The simple explanation for this is that they were the first descendants of Adam and Eve, whom God Himself created and designed to live forever. They therefore inherited this genetic longevity. When God did not continue replenishing

it, it gradually waned over a period of twenty generations, ending with Abraham.

The mystical explanation is as follows: As we have seen, the first twenty generations of humanity were sustained by God's attribute of indiscriminate kindness<sup>236</sup> that transcends reason and the orderly descent of Divine energy through creation (*seder hishtalshelut*). Human virtue and vice are irrelevant to indiscriminate kindness;<sup>237</sup> sin is not punished as severely as appropriate and sinners can therefore benefit from God's beneficence even though they do not rightly deserve to. Hence this era is referred to as the "two millennia of chaos."<sup>238</sup>

The reason these generations were sustained by God's indiscriminate kindness was because there was no one to elicit God's beneficence by virtue of good behavior. This being the case, God chose

233. See Rabbi Shneur Zalman of Liadi, *Hilchot Talmud Torah* 4:3; *Tanya*, chapter 39. 234. *Likutei Sichot* vol. 3, pp. 756-757. 235. *Or HaTorah, Bereishit*, vol. 4, 749a. 236. According to the Talmud (*Pesachim* 118a), the first twenty-six generations until the Giving of the Torah received sustenance from God's indiscriminate kindness. After the twentieth generation, when the era of Torah began with Abraham, the world continued to receive sustenance from the level of kindness, but not as much as it did during the first twenty generations. 237. See Job 35:6-7. 238. See *Sanhedrin* 97a.

26 Yoktan was the father of Almodad, Shelef, Chatzarmavet (“the Court of Death,” which besides being his given name was also the name of his city<sup>231</sup>), Yerach,

27 Hadoram, Uzal, Diklah,

28 Oval, Avimael, Sheva,

29 Ophir, Chavilah, and Yovav; all these were the sons of Yoktan, who merited fathering all these numerous extended families because of his humility.

30 Their dwelling place extended from Mesha towards Sephar, the eastern mountain.

31 These are the descendants of Shem, according to their clans and languages, by their lands and their nations.

32 These mentioned above were the families of Noah’s sons, in their order of birth, by their nations, and from them the nations eventually dispersed over the earth after the Flood.

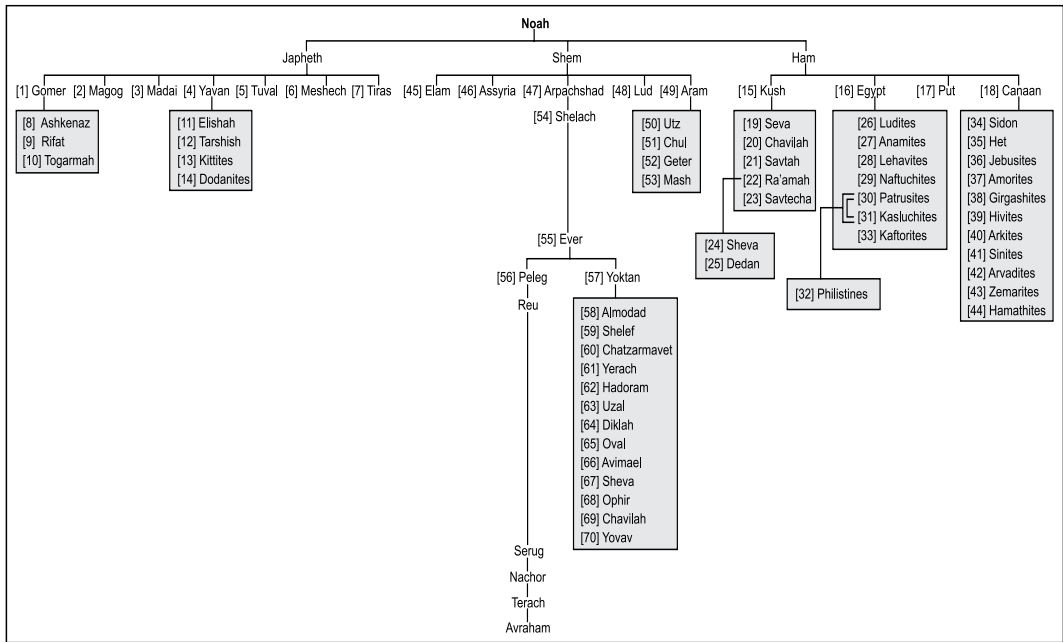

Figure 10: The Seventy Nations

CHASIDIC INSIGHTS

31 **God’s anger...had been increasingly intensifying:** The ten generations between Adam and Noah behaved immorally, so God brought the Flood to wipe them out. There were also ten immoral generations between Noah and Abraham, but God did not wipe them out; He simply gave the reward that was due them to Abraham.<sup>232</sup> Why was Abraham deemed worthy of receiving the reward for the generations that preceded him, whereas Noah was not?

The answer lies in the fact that the generations that preceded Noah did not *deserve* any reward. And even if they would have deserved some reward, Noah was

not worthy of receiving it, since he neither edified his contemporaries nor prayed for them.

In contrast, the generations that preceded Abraham *did* deserve reward for co-existing harmoniously and treating each other kindly. But their simultaneous rebellion against God neutralized their merits for this reward. The Divine blessings elicited through their good deeds were absorbed by the forces of evil.

(Similarly, when we study the Torah and perform the commandments without having repented for our sins, we do elicit Divine blessings. But our sins block them from reaching us; instead, they are diverted to the neg-

231. *Likutei Sichot*, vol. 5, p. 287. 232. *Avot* 5:1.

ONKELOS

11 וְהָיָה כָּל־הָאָרֶץ שְׂפָה אַחַת וּדְבָרִים אֶחָדִים:  
 2 וְהָיָה בְּנִסְעֵם מִקְדָּם וַיִּמְצְאוּ בְקִעָה בְּאֶרֶץ שְׁנַעַר וַיֵּשְׁבוּ  
 שָׁם: 3 וַיֹּאמְרוּ אִישׁ אֶל־רֵעֵהוּ הֲבֵה נִלְבְּנָה לְבָנִים  
 וְנִשְׂרְפָה לְשֵׂרָפָה וְתֵהִי לָהֶם הַלְבְּנָה לְאַבְן וְהַחֲמֹר הָיָה  
 לָהֶם לְחֵמֶר:

שביעי 11:1 וְהָיָה כָּל־הָאָרֶץ שְׂפָה אַחַת וּדְבָרִים אֶחָדִים:  
 2 וְהָיָה בְּנִסְעֵם מִקְדָּם וַיִּמְצְאוּ בְקִעָה בְּאֶרֶץ שְׁנַעַר וַיֵּשְׁבוּ  
 שָׁם: 3 וַיֹּאמְרוּ אִישׁ אֶל־רֵעֵהוּ הֲבֵה נִלְבְּנָה לְבָנִים  
 וְנִשְׂרְפָה לְשֵׂרָפָה וְתֵהִי לָהֶם הַלְבְּנָה לְאַבְן וְהַחֲמֹר הָיָה  
 לָהֶם לְחֵמֶר:

RASHI

הקדום, ונסעו משם לתור להם מקום להחזיק את כלם, ולא מצאו אלא שְׁנַעַר: 3 איש אל רעהו. אמה לאמה, מצרים לכוש, וכוש לפוט, ופוט לכנען: הבה. הזמינו עצמכם. כל "הבה" לשון הזמנה הוא, שמיכנים עצמן ומתחברים למלאכה או לעצה או למשא. "הבה" הזמינו, אפריילייר בלעז<sup>64</sup>: לַבְּנִים. שאין אבנים בכבל, שהיא בקעה: וְנִשְׂרְפָה לְשֵׂרָפָה. כך עושין הלבנים שקורים טיולי"ש<sup>65</sup>, שורפים אותם בכבשן: לְחֵמֶר. לטוח הקיר:

1 שפה אחת. לשון הקדש: וּדְבָרִים אֶחָדִים. באו בעצה אחת, ואמרו: לא כל הימנו שְׁיָבוֹר לוֹ אֶת הָעֲלִיּוֹנִים, נעלה לרקיע ונעשה עמו מלחמה. דבר אחר: על יחידו של עולם. דבר אחר: "ודברים אחדים", דברים חדים, אמרו: אחת לאלף ושש מאות חמשים ושש שנים הרקיע מתמוטט, כשם שעשה בימי המבול, באו ונעשה לו סמוכות: 2 וְהָיָה בְּנִסְעֵם מִקְדָּם. שהיו יושבים שם, כדכתיב למעלה<sup>66</sup>: "ויהי מושבם וגו' הר

67. י. ל. 68. להכוין. 69. רעפים.

CHASIDIC INSIGHTS

tive things could have (and therefore *should* have) been accomplished. After all, we are allotted only a certain amount of time on earth in which to accomplish our Divine mission. We must therefore, like Abraham, not only destroy the negative, but also salvage the past through rectifying it and completing what was lacking, thereby transforming darkness into light.<sup>245</sup>

Another lesson that we learn from noting the differences between Noah and Abraham: The generations that preceded us prepared the world for the messianic era,

when the purpose of all of creation will be realized.<sup>246</sup> The task of our generation is to bring all their work to fruition. We must therefore emulate Abraham, lovingly befriending all Jews and awakening their innate connection to Judaism. This will reveal the holy sparks that lie hidden within them. And then, like Abraham, we will "receive the reward for them all," by channeling these sparks toward their ultimate purpose: the true and complete redemption.<sup>247</sup>

INNER DIMENSIONS

[continued...] to overlook these generations' lack of merits. With the advent of Abraham, however, God's beneficence could once again be earned. The transcendent aspect of God's energy began to be absorbed by holiness, thereby preventing the forces of evil from siphoning off the transcendent energy as it did during the first twenty generations. Abraham thus began the "two millennia of Torah,"<sup>248</sup> in which the world no longer had to receive its sustenance from God's indiscriminate kindness (at least not to the same extent as it did during the first twenty generations).

This internalization and absorption of God's transcendent energy is alluded to in the final *nun* that

concludes this *parashah* and that separates between what occurred before it and what was to occur after it. On the one hand, the numerical value of the *nun* is fifty, alluding to the transcendent energy of the "fiftieth gate of understanding." On the other hand, the final *nun*'s elongated shape, which extends below the line of the other letters, connotes drawing down this lofty energy and internalizing it in reality.

The "two millennia of Torah" thus serve as a preparation for the "two millennia of the Messiah," when all transcendent energies will be internalized, leading to the fulfillment of the promise:<sup>249</sup> "I shall remove the spirit of impurity from the earth."<sup>250</sup>

245. *Likutei Sichot*, vol. 15, pp. 70-74. 246. *Tanya*, chapter 36. 247. *Likutei Sichot*, vol. 3, p. 757. 248. See *Sanhedrin*, *ibid.* and *Avodah Zarah* 9a. 249. *Zachariah* 13:2. 250. *Likutei Sichot*, vol. 15, pp. 63-69.

## The Tower of Babel

- ◆ **Seventh Reading 11:1** Deliberately ignoring God's instructions to Noah that they disperse and populate world, Noah's descendants chose to live together in the mountainous region around Mount Ararat. Acutely aware that God had brought on the Flood because of the world's antisocial behavior, they reasoned that the best way to garner God's favor and beneficence was to show Him they could live together in unity.<sup>239</sup> **The whole population of the world was united, speaking one language, but they were also united in a common, ill-advised cause, led by Nimrod.** Nimrod<sup>240</sup> convinced them that God was being presumptuous by relegating humanity to the earth while reserving heaven for Himself alone; and it was therefore necessary to show God that they were challenging this arrogance by building a tower that would reach upward into heaven, His domain. Furthermore, he convinced them that the Flood was a simply a natural, periodic occurrence that would repeat itself every 1656 years, and for this reason, too, they should build a tower that would reach into the clouds, so they could take measures to control the rainfall, if necessary.<sup>241</sup> They therefore had to look for a place where they could all congregate and build such a tower.

**2 When they migrated from the mountains in the east in search of such a place, they found a valley in the land of Shinar large enough for these purposes and they settled there** (see Figure 11).

**3 But there were no stones in this valley with which to build, so they said to one another, "Come, let us mold bricks and fire them." The bricks they made were as hard as stone,<sup>242</sup> and the clay served them for mortar with which to plaster the walls.**

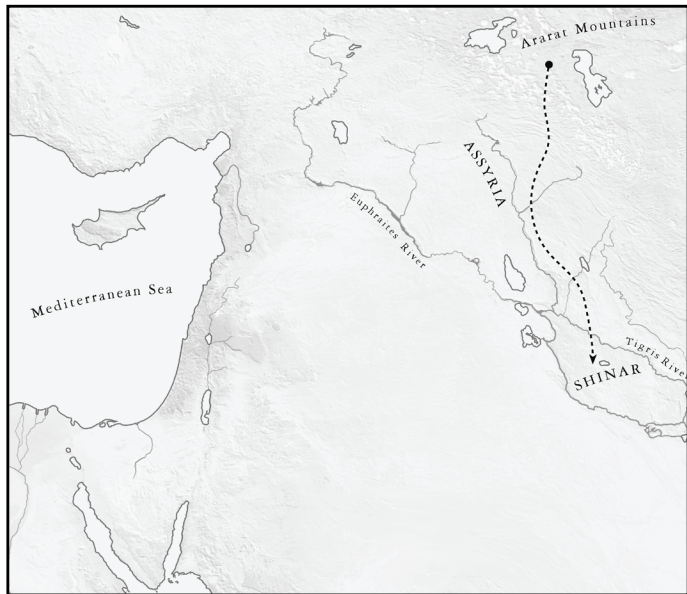

Figure 11: The Migration of the Generation of the Dispersion

### ∞ CHASIDIC INSIGHTS ∞

ceived the reward for them all."

These two eras in world history are mirrored in the individual history of every person, since every person is a microcosm of creation.<sup>243</sup> There are occasions when, sadly, we may squander a period of precious time on ungodly activities, yet still enjoy material success. This deludes us into believing that such a situation can con-

tinue indefinitely. The truth is, though, that this material success is only thanks to God's patience, which will eventually come to an end.<sup>244</sup> We must therefore "bring a flood" upon these ungodly activities and destroy them completely, just as God destroyed the first ten generations who were completely evil.

But this is not enough. During that wasted time, posi-

239. *Torah Or* 11b. 240. Above, 10:8-10. 241. *Hitva'aduyot* 5746, vol. 1, p. 463-464. 242. *Likutei Sichot*, vol. 11, p. 106, note 37. 243. *Tanchuma, Pekudei* 3, et al. 244. See *Kuntres U'Mayan* 11:2 ff.

— ONKELOS —

4 ואמרו הבו נבני לנא קרתא ומגדלא ורישה מטי עד צית שמאי ונעביד לנא שום דלמא נתבדר על אפי כל ארעא: 5 ואתגלי יי לאתפרעא על עובדי קרתא ומגדלא די בנו בני אנשא: 6 ואמר יי הא עמא חד ולשן חד לכלהון ודין דשריו למעבד וכען לא יתמנע מנהון כל די חשיבו למעבד: 7 הבו נתגלי ונבלבל תמן לשנהון דלא ישמעון אנש לשן חברה: 8 ובדר יי יהדון מתמן על אפי כל ארעא ואתמנעו מלמבני קרתא: 9 על כן קרא שמה בכל ארי תמן בבל יי לשן כל ארעא ומתמן בדריון יי על אפי כל ארעא: 10 אליו תולדת שם שם בר מאה שנין ואוליד ית ארפכשד תרתין שנין בטר טופנא:

4 ויאמרו הבה | נבנה לנו עיר ומגדל וראשו בשמים ונעשה לנו שם פון נפון על פני כל הארץ: 5 וירד יהוה לראת את העיר ואת המגדל אשר בנו בני האדם: 6 ויאמר יהוה הן עם אחד ושפה אחת לכלם וזה החלם לעשות ועתה לא יבצר מהם כל אשר יזכו לעשות: 7 הבה נרדה ונבלה שם שפתם אשר לא ישמעו איש שפת רעהו: 8 ויפיץ יהוה אתם משם על פני כל הארץ ויחדלו לבנת העיר: 9 עליבן קרא שמה בכל בני-שם בלל יהוה שפת כל הארץ ומשם הפיצם יהוה על פני כל הארץ: פ

10 אלה תולדת שם שם בן-מאת שנה ויולד את-ארפכשד שנתים אחר המבול:

— RASHI —

נרדה: ונבלה. ונבלבל. גו"ן משמש בלשון רבים, וה"א אחרונה יתרה כה"א של "נרדה": לא ישמעו. זה שואל לבנה וזה מכיא טיט, וזה עומד עליו ופוצע את מוחו: 8 ויפיץ ה' אתם משם. בעולם הזה. מה שאמרו "פון נפון" נתקנים עליהם, הוא שאמר שלמה<sup>66</sup>: "מגורת רשע היא תבואנו": 9 ומשם הפיצם. למד, שאין להם חלק לעולם הבא. וכי אי זו קשה, של דור המבול או של דור הפלגה, אלו לא פשטו יד בעקר ואלו פשטו יד בעקר כביכול להלחם בו, ואלו נשטפו ואלו לא נאבדו מן העולם? אלא, שדור המבול היו גזלנים והיתה מריבה ביניהם, לכך נאבדו. ואלו היו נוהגים אהבה ורעות ביניהם, שנאמר: "שפה אחת ודברים אחדים". למדת, ששנאוי המחלוקת וגדול השלום: 10 שם בן מאת שנה. בשהוליד את ארפכשד שנתים אחר המבול:

4 פון נפון. שלא יביא עלינו שום מכה להפיצנו מכאן: 5 וירד ה' לראות. לא הצרף לך, אלא בא למדוד לדנינים שלא ירשיעו הנהון עד שיראו ויבינו. מדרש רבי תנחומא<sup>66</sup>: בני האדם. אלא בני מי, שמא בני חמורים וגמלים? אלא, בני אדם הראשון שכפה את הטובה, ואמר<sup>67</sup>: "האשה אשר נתתה עמדי". אף אלו כפו בטובה, למרוד במי שהשפיעם טובה ומלטם מן המבול: 6 הן עם אחד. כל טובה זו יש עמהן, שעם אחד הם ושפה אחת לכלן, ודרך זה החלו לעשות: החלם. כמו: "אמרם" "עשותם", התחילו הם לעשות: לא יבצר מהם וגו' לעשות. בתמיה. "יבצר" לשון מניעה, פתרגומו. ודומה לו<sup>68</sup>: "יבצר רוח נגידים": 7 הבה נרדה. בבית דינו נמלה, מענותנותו היתרה: הבה. מדה פנגד מדה, הם אמרו: "הבה נבנה", והוא פנגדם מדרד ואמר: "הבה

63. נח יח. 64. בראשית ג, יב. 65. תהלים עו, יג. 66. משלי י, כד.

## The Line of Shem

10 Having concluded recounting how the seventy descendants of Noah became separate nations, the Torah continues its chronicle of the lineage of Shem.<sup>254</sup> It will be noticed in this chronicle that the human lifespan became increasingly shorter after the Flood.<sup>255</sup> This is because after the Flood, God no longer sustained the world without regard to human merit, as He had done *before* the Flood. Rather, God henceforward made humanity's success in self-refinement the central factor in eliciting Divine beneficence. Although this ensured that God would never again wipe out the world,<sup>256</sup> it attenuated the intensity of the flow of Divine life force, resulting in shorter life-expectancy (see figure 12).<sup>257</sup>

4 They said, “Come, let us build ourselves a city, and a tower whose top shall reach into the sky. Let us make ourselves a name, so that we will not be scattered by God all over the face of the earth and thereby lose the merit that earns us His beneficence.” It was at this point that the Assyrians separated themselves from Nimrod and migrated to the north.<sup>251</sup>

5 In the year 1996, **GOD descended to see the city and the tower that the sons of man had built.** Although He knew what they were doing, He wished to demonstrate that a judge should never pass sentence before thoroughly examining the case.

6 **GOD said, “They possess all the advantages and conveniences of being a single people, all having one language—and this is what they have begun to do?! So now, should they not be prevented from doing that which they planned to do?”**

7 In order to demonstrate how a person should always humbly seek the counsel of others before deciding upon a course of action—even if they are of lesser status <sup>252</sup>—He consulted with His heavenly court, saying, “**Come, let us descend and confuse their speech there, so that one person will not understand another’s speech.** This will make them quarrel with one another and break up into separate groups, the very thing they feared would happen to them. Although they have declared war on Me, and thus, theologically, their sin is greater than the sins of the generation of the Flood, I will not destroy them, because at least they were united and acted peacefully towards one another. In contrast, the people of the Flood were contentious and robbed from one another. I value peace among My creatures even more than I value the respect they owe Me.”

8 The heavenly court agreed. Except for Shem and his family, Noah’s descendants suddenly forgot how to speak their original language, Hebrew, and each clan began speaking its own language. Not being able to communicate with each other, they dispersed. In this way, **GOD scattered them from that place all over the face of the earth, and they stopped building the city.** The descendants of Japheth and Ham migrated westward, leaving the descendants of Shem in the regions east of the Euphrates River.<sup>253</sup>

9 **It was therefore named Babel, because this was the place where GOD confused (balal) the whole world’s language. From there GOD dispersed them over all the face of the earth and revoked their privilege of entering the afterlife, as well.**

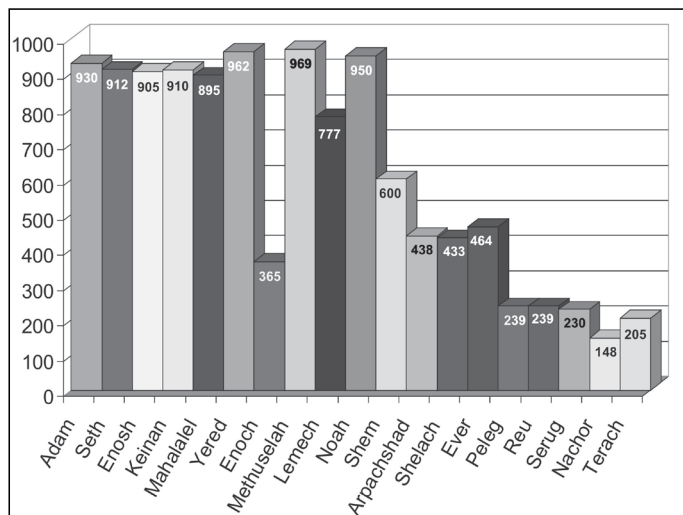

Figure 12: The Shortening of Life Expectancy

251. Above, 10:11. 252. *Bereishit Rabbah* 8:8. 253. Above, 10:21. 254. Above, 10:21-31. 255. Compare above, chapter 5. 256. Above, 9:13. 257. *Likutei Sichot*, vol. 15, p. 54.

— ONKELOS —

11 וַחֲיָא שֵׁם בְּתַר דְּאוֹלִיד יְת אַרְפַּכְשָׁד חֲמִשׁ מְאָה שְׁנִין וְאוֹלִיד בְּנִין וּבְנָן: 12 וְאַרְפַּכְשָׁד חֲיָא תְּלַתִּין וַחֲמִשׁ שְׁנִין וְאוֹלִיד יְת שְׁלַח: 13 וַחֲיָא אַרְפַּכְשָׁד בְּתַר דְּאוֹלִיד יְת שְׁלַח אַרְבַּע מְאָה וּתְלַת שְׁנִין וְאוֹלִיד בְּנִין וּבְנָן: 14 וְשְׁלַח חֲיָא תְּלַתִּין שְׁנִין וְאוֹלִיד יְת עֶבֶר: 15 וַחֲיָא שְׁלַח בְּתַר דְּאוֹלִיד יְת עֶבֶר אַרְבַּע מְאָה וּתְלַת שְׁנִין וְאוֹלִיד בְּנִין וּבְנָן: 16 וַחֲיָא עֶבֶר תְּלַתִּין וְאַרְבַּע שְׁנִין וְאוֹלִיד יְת פֶּלֶג: 17 וַחֲיָא עֶבֶר בְּתַר דְּאוֹלִיד יְת פֶּלֶג אַרְבַּע מְאָה וּתְלַתִּין שְׁנִין וְאוֹלִיד בְּנִין וּבְנָן: 18 וַחֲיָא פֶּלֶג תְּלַתִּין שְׁנִין וְאוֹלִיד יְת רֵעָה: 19 וַחֲיָא פֶּלֶג בְּתַר דְּאוֹלִיד יְת רֵעָה מֵאֲתָן וַחֲשַׁע שְׁנִין וְאוֹלִיד בְּנִין וּבְנָן: 20 וַחֲיָא רֵעָה תְּלַתִּין וַחֲרַתִּין שְׁנִין וְאוֹלִיד יְת שְׂרוּג: 21 וַחֲיָא רֵעָה בְּתַר דְּאוֹלִיד יְת שְׂרוּג מֵאֲתָן וַחֲשַׁע שְׁנִין וְאוֹלִיד בְּנִין וּבְנָן: 22 וַחֲיָא שְׂרוּג תְּלַתִּין שְׁנִין וְאוֹלִיד יְת נַחֲוֹר: 23 וַחֲיָא שְׂרוּג בְּתַר דְּאוֹלִיד יְת נַחֲוֹר מֵאֲתָן שְׁנִין וְאוֹלִיד בְּנִין וּבְנָן: 24 וַחֲיָא נַחֲוֹר עֶשְׂרִין וַחֲשַׁע שְׁנִין וְאוֹלִיד יְת תְּרַח: 25 וַחֲיָא נַחֲוֹר בְּתַר דְּאוֹלִיד יְת תְּרַח מְאָה וַחֲשַׁע עֶשְׂרִין שְׁנִין וְאוֹלִיד בְּנִין וּבְנָן: 26 וַחֲיָא תְּרַח שְׁבַעִין שְׁנִין וְאוֹלִיד יְת אַבְרָם יְת נַחֲוֹר וְיְת הָרָן: 27 וְאַלְפִין תְּיֻלְדַת תְּרַח הָרָן אוֹלִיד יְת אַבְרָם יְת נַחֲוֹר וְיְת הָרָן וְהָרָן אוֹלִיד יְת לוֹט:

11 וַיְחִי־שָׁם אַחֲרֵי הוֹלִידוֹ אֶת־אַרְפַּכְשָׁד חֲמִשׁ מֵאוֹת שָׁנָה וַיּוֹלֶד בָּנִים וּבָנוֹת: 8

12 וְאַרְפַּכְשָׁד חֵי חֲמִשׁ וּשְׁלֹשִׁים שָׁנָה וַיּוֹלֶד אֶת־שְׁלַח:

13 וַיְחִי אַרְפַּכְשָׁד אַחֲרֵי הוֹלִידוֹ אֶת־שְׁלַח שְׁלֹשׁ שָׁנִים וְאַרְבַּע מֵאוֹת שָׁנָה וַיּוֹלֶד בָּנִים וּבָנוֹת: 8

14 וְשְׁלַח חֵי שְׁלֹשִׁים שָׁנָה וַיּוֹלֶד אֶת־עֶבֶר: 15 וַיְחִי־שְׁלַח אַחֲרֵי הוֹלִידוֹ אֶת־עֶבֶר שְׁלֹשׁ שָׁנִים וְאַרְבַּע מֵאוֹת שָׁנָה וַיּוֹלֶד בָּנִים וּבָנוֹת: 8

16 וַיְחִי־עֶבֶר אַרְבַּע וּשְׁלֹשִׁים שָׁנָה וַיּוֹלֶד אֶת־פֶּלֶג: 17 וַיְחִי־עֶבֶר אַחֲרֵי הוֹלִידוֹ אֶת־פֶּלֶג שְׁלֹשִׁים שָׁנָה וְאַרְבַּע מֵאוֹת שָׁנָה וַיּוֹלֶד בָּנִים וּבָנוֹת: 8

18 וַיְחִי־פֶלֶג שְׁלֹשִׁים שָׁנָה וַיּוֹלֶד אֶת־רֵעָה: 19 וַיְחִי־פֶלֶג אַחֲרֵי הוֹלִידוֹ אֶת־רֵעָה תֵשַׁע שָׁנִים וּמֵאֲתָיִם שָׁנָה וַיּוֹלֶד בָּנִים וּבָנוֹת: 8

20 וַיְחִי רֵעָה שְׁתַּיִם וּשְׁלֹשִׁים שָׁנָה וַיּוֹלֶד אֶת־שְׂרוּג: 21 וַיְחִי רֵעָה אַחֲרֵי הוֹלִידוֹ אֶת־שְׂרוּג שִׁבְעַת שָׁנִים וּמֵאֲתָיִם שָׁנָה וַיּוֹלֶד בָּנִים וּבָנוֹת: 8

22 וַיְחִי שְׂרוּג שְׁלֹשִׁים שָׁנָה וַיּוֹלֶד אֶת־נַחֲוֹר: 23 וַיְחִי שְׂרוּג אַחֲרֵי הוֹלִידוֹ אֶת־נַחֲוֹר מֵאֲתָיִם שָׁנָה וַיּוֹלֶד בָּנִים וּבָנוֹת: 8

24 וַיְחִי נַחֲוֹר תֵשַׁע וְעֶשְׂרִים שָׁנָה וַיּוֹלֶד אֶת־תְּרַח: 25 וַיְחִי נַחֲוֹר אַחֲרֵי הוֹלִידוֹ אֶת־תְּרַח תֵשַׁע־עֶשְׂרֵה שָׁנָה וּמֵאֲתָיִם שָׁנָה וַיּוֹלֶד בָּנִים וּבָנוֹת: 8

26 וַיְחִי־תְּרַח שְׁבַעִים שָׁנָה וַיּוֹלֶד אֶת־אַבְרָם וְאֶת־הָרָן: 27 וְאַלְהָה תּוֹלְדַת תְּרַח הָרָן אוֹלִיד אֶת־אַבְרָם וְאֶת־הָרָן וְהָרָן הוֹלִיד אֶת־לוֹט:

27 The narrative now focuses on the history of Terach's family. The following are the descendants of Terach: Terach was the father of Abram, Nachor, and Haran, and Haran was the father of Lot and of two daughters, Sarai and Milkah.

his father, and his next eldest son was Haran. Abram was born from one wife and Nachor and Haran from another.

27 The narrative now focuses on the history of Terach's family. The following are the descendants of Terach: Terach was the father of Abram, Nachor, and Haran, and Haran was the father of Lot and of two daughters, Sarai and Milkah.

The following are the descendants of Shem: Shem was 100 years old when he fathered his third son, Arpachshad, in the year 1658, two years after the Flood began.

11 Shem lived 500 years after he fathered Arpachshad, and he fathered other sons and daughters before he died in the year 2158, at the age of 600.

12 Arpachshad was 35 years old when he fathered a son, Shelach, in the year 1693.

13 Arpachshad lived 403 years after Shelach was born, and he fathered other sons and daughters before he died in the year 2096, at the age of 438.

14 Shelach was 30 years old when he fathered a son, Ever, in the year 1723.

15 Shelach lived 403 years after he fathered Ever, and he fathered other sons and daughters before died in the year 2126, at the of 433.

16 Ever was 34 years old when he fathered a son, Peleg, in the year 1757.

17 Ever lived 430 years after he fathered Peleg, and he fathered other sons and daughters before he died in the year 2187, at the age of 464. After the dispersion, Shem saw that humanity was again drifting away from God's original instructions to humanity. He therefore founded, together with his great-grandson Ever, an academy whose purpose it was to preserve the corpus these teachings—which God would later give formally as the Torah—and teach them to whomever was interested enough to seek them out. Together with the God's teachings, this academy also preserved the knowledge of the world's original language, Hebrew. This language was kept secret, since Shem and Ever understood from the incident of the Tower of Babel that God felt that the general population was no longer worthy of using it. Shem settled in the city of Salem (which would later be renamed Jerusalem).<sup>258</sup>

18 Peleg was 30 years old when he fathered a son, Reu, in the year 1787.

19 Peleg lived 209 years after he fathered Reu, and he fathered other sons and daughters before he died in the year 1996—the year of the dispersion<sup>259</sup>—at the age of 239.

20 Reu was 32 years old when he had a son, Serug, in the year 1819.

21 Reu lived 207 years after he fathered Serug, and he fathered other sons and daughters before he died in the year 2026, at the age of 239.

22 Serug was 30 years old when he fathered a son, Nachor, in the year 1849.

23 Serug lived 200 years after he fathered Nachor, and he fathered other sons and daughters before he died in the year 2049, at the age of 230.

24 Nachor was 29 years old when he fathered a son, Terach, in the year 1878.

25 Nachor lived 119 years after he fathered Terach, and he fathered other sons and daughters before he died in the year 1997, at the age of 148.

26 Terach was 70 years old when, in the year 1948, he fathered a son, whom he named Abram ("the Prince of Aram"). His eldest son was Nachor, named after

---

<sup>258</sup>. Below, 14:18. <sup>259</sup>. Above, 10:25.

— ONKELOS —  
 28 ומית הָרֶן על אפי תרח אָבוהי  
 באַרע ילדוּתהּ באַורא דְכַשְׁדָּאי:  
 29 וְנָסִיב אַבְרָם וְנָחֹר לְהוֹן נָשִׁין  
 שׁוּם אִתָּהּ אַבְרָם שְׂרִי וְשׁוּם אִתָּהּ  
 נָחֹר מִלְכָּה בַת הָרֶן אָבוּהָא  
 דְּמִלְכָּה וְאָבוּהָא דְּיִסְכָּה: 30 וְהוּת  
 שְׂרִי עֲקָרָה לִית לָהּ וְלָדָּ: 31 וְדַבֵּר  
 תְּרַח וְיַת אַבְרָם בְּרָהּ וְיַת לוֹט בַּר  
 הָרֶן בַּר בְּרָהּ וְיַת שְׂרִי כַלְתָּהּ אִתָּהּ  
 אַבְרָם בְּרָהּ וְנִפְקוּ עִמָּהוֹן מֵאֹרָא  
 דְּכַשְׁדָּאי לְמִיּוֹל לְאַרְעָא דְּכַנְעַן  
 וְאָתוּ עַד הָרֶן וְיַחֲבִיבוּ תַמְנָן:

28 וַיִּמָּת הָרֶן עַל־פְּנֵי תְּרַח אָבִיו בְּאֶרֶץ מִוְלַדְתּוֹ בְּאֹר  
 כַּשְׁדִּים:

מפסיר 29 וַיִּקַּח אַבְרָם וְנָחֹר לָהֶם נָשִׁים שֵׁם אִשְׁתִּי  
 אַבְרָם שְׂרִי וְשֵׁם אִשְׁתִּי־נָחֹר מִלְכָּה בַת־הָרֶן אִבְי־מִלְכָּה  
 וְאָבִי יִסְכָּה: 30 וַתְּהִי שְׂרִי עֲקָרָה אֵין לָהּ וָלָד: 31 וַיִּקַּח  
 תְּרַח אֶת־אַבְרָם בְּנוֹ וְאֶת־לוֹט בֶּן־הָרֶן בֶּן־בְּנוֹ וְאֶת שְׂרִי  
 כַלְתּוֹ אִשְׁתִּי אַבְרָם בְּנוֹ וַיֵּצְאוּ אֹתָם מֵאֹר כַּשְׁדִּים לְלַכְת  
 אֶרְצָה כְּנַעַן וַיָּבֹאוּ עַד־הָרֶן וַיִּשְׁבּוּ שָׁם:

— RASHI —

כַּשְׁדִּים". ומנחם בן סרוק פֵּרַשׁ: "אור" — בקעה, וכן:  
 "בְּאֵרִים בְּבֵדוּ ה'", וכן<sup>267</sup>: "מְאוּרַת צַפְעוֹנִי", כַּל חוֹר וְבִקְעָה  
 עֵמוֹק קְרוּי "אור": 29 יִסְכָּה. זו שְׂרָה, עַל שֵׁם שְׁסוּכָה  
 בְּרוּחַ הַקֶּדֶשׁ, וְשֶׁהִבֵּל סוֹכִין בְּיַפְיָהּ. ועוד, "יִסְכָּה" לְשׁוֹן  
 "נְסִיכוֹת", כְּמוֹ "שְׂרָה" לְשׁוֹן "שְׂרָרָה": 31 וַיֵּצְאוּ אֹתָם.  
 וַיֵּצְאוּ תְּרַח וְאַבְרָם עִם לוֹט וְשְׂרִי:

28 על פני תרח אביו. בחזי אביו. ומדרש אגדה<sup>268</sup>: יש  
 אומרים, שעל ידי אביו מת, שקבל תרח על אברם בנו  
 לפני נמרוד על שבתת את צלמיו, והשליכו לכבשן  
 האש, והרן יושב ואומר בלבבו: אם אברם נוצח אני  
 משל, ואם נמרוד נוצח אני משל. וכשנצל אברם,  
 אמרו לו להרן: משל מי אתה? אמר להם הרן: משל  
 אברם אני. השליכוהו לכבשן האש ונשרף. וזהו "אור

72. בראשית רבה לח, יג. 73. ישעיה כד, טו. 74. שם יא, ח.

and Sarai began to spread monotheism and gradually gathered around them a following of new believers.<sup>266</sup> Their activities quelled God’s anger, which had been increasingly intensifying with the spread of idolatry after the Flood.<sup>267</sup>

In the year 2018, when Abram was 70 years old, he visited Canaan briefly.<sup>268</sup> As will be described below,<sup>269</sup> God appeared to him while he was there and promised to give

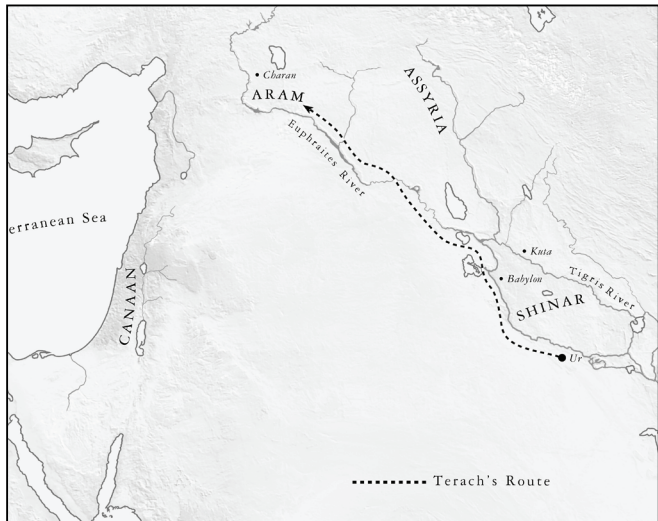

Figure 14: Terach Moves to Charan

him Canaan and to make him the progenitor of the chosen people. Abram then returned to Charan. Since his father, Terach, had not wanted to accompany him to Canaan, Abram had to return to Charan to continue to care for him, for until God

266. Below, 12:5. 267. *Likutei Sichot*, vol. 15, pp. 63-69. 268. Rashi on Exodus 12:40; *Likutei Sichot*, vol. 15, p. 202, notes 17 and 23, vol. 30, p. 233, note 37. 269. 15:7-21.

28 Abram grew up during the period after Nimrod and his followers had already migrated to the Plain of Shinar. Although raised as an idolater, Abram already perceived the folly of idol worship in his early childhood. When Abram purposely broke his father's idols, the latter brought him to Nimrod, who threw him into a fiery furnace. God miraculously saved Abram, and he emerged from the furnace unscathed. Abram's older brother, Haran, decided that he would side with whoever would win this confrontation. Upon seeing that Abram emerged unharmed, Haran declared himself to be on his side, whereupon Nimrod then cast him, too, into the furnace, and he died there. Thus, **Haran died during the lifetime of his father, Terach, in the land of his birth**, and, in fact, he died *because* his father, Terach, took Abram to Nimrod. The news of this incident became so widespread that Nimrod became known as Amrafel ("He who said, 'Fall [into the furnace!]'")<sup>260</sup> and the city where it occurred became known as **Ur ("the fire") of the Kasdites**.<sup>261</sup> Another meaning of the word *Ur* is "valley," since it was the capital of Nimrod's kingdom in the Valley of Shinar.

- ◆ **Maftir 29 Abram and Nachor married. The name of Abram's wife was Sarai, and the name of Nachor's wife was Milkah, the daughter of Haran, who was the father of Milkah and her sister Sarai, who was also known as Yiskah,** meaning "[far]-looking," since she was gifted with Divine inspiration and could foretell the future; "[good]-looking," since everyone enjoyed gazing at her beauty; and "royal dignity," parallel to her other name, Sarai, which means "my princess." Abram and Nachor, the two brothers, thus both married their nieces, two sisters—the daughters of their brother, Haran (see Figure 13).

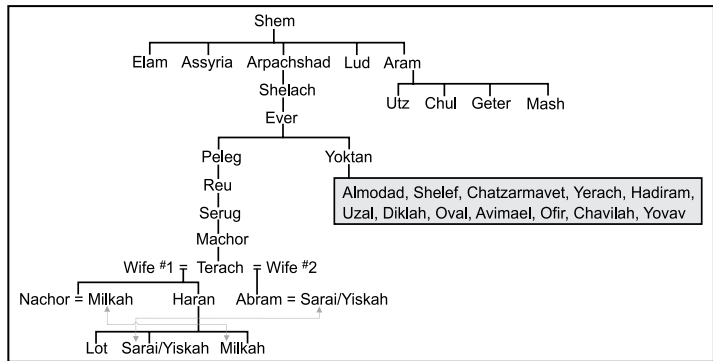

Figure 13: The Line of Shem

30 **Sarai was barren; she had no child.** And according to Abraham's astrological calculations, he would never have any children through her.<sup>262</sup>

31 The incident of the fiery furnace<sup>263</sup> convinced Terach to himself espouse monotheism.<sup>264</sup> But because he did not want to acknowledge his repentance publicly,<sup>265</sup> he instead decided to move to a place where he would not be a public figure, thus avoiding the need to participate in public idol worship. **Terach took his son Abram; his grandson Lot, the son of Haran; and his daughter-in-law Sarai, the wife of his son Abram.** Terach and Abram left Ur of the Kasdites with Lot and Sarai, heading toward Canaan. They left Nachor and Milkah behind in Ur. On the other hand, Terach knew that moving all the way to Canaan would entail espousing monotheism publicly, and he was not ready to do this. So **they came as far as the city of Charan in Aram, and settled there** (see figure 14). While in Charan, Abram

260. Rashi on 14:1, below. 261. One of Abraham's nephews was Nachor's son Kesed. See below, 22:22. 262. Rashi on 15:5, below. 263. *Likutei Sichot*, vol. 15, p. 63, note 5. 264. Rashi on 15:15. 265. *Likutei Sichot*, vol. 15, p. 63, note 6.

— ONKELOS —  
 32 והיו יומי תרח מאתן וחמש  
 שנים ומית תרח בחרן:

32 ויהיו ימי־תרח חמש שנים ומאתים שנה ומית תרח

### בְּחֶרֶן: פ פ פ

קנ"ג פסוקים. בצלא"ל סימן.

— RASHI —

לכל, ויאמרו: לא קים אברם את כבוד אביו, שהניחו  
 זקן והלך לו. לפיכך קראו הכתוב מת, שהרשעים אף  
 בחייהם קרוים מתים, והצדיקים אף במיתתן קרוים  
 חיים, שנאמר: "ובניהו בן יהונדע בן איש חי": בחרן.  
 הנו"ן הפוכה, לומר לה: עד אברם חרון אף של מקום  
 בעולם:

חסלת פרשת נח

32 ומית תרח בחרן. לאחר שיצא אברם מחרן ובא  
 לארץ כנען, והיה שם יותר מששים שנה, שהרי כתיב:  
 "ואברם בן חמש שנים ושבעים שנה בצאתו מחרן",  
 ותרח בן שבעים שנה היה כשנולד אברם, הרי מאה  
 ארבעים וחמש לתרח בשיצא אברם מחרן, עדין  
 נשארו משנותיו הרבה. ולמה הקדים הכתוב מיתתו  
 של תרח ליציאתו של אברם? שלא יהא הדבר מפרסם

70. בראשית יב, ד. 71. שמואל"ב כג, כ.

instructed him explicitly to leave, he was still legally bound to observe the commandment of parental respect.<sup>270</sup>

By this time, Abram had learned of God's original instructions to humanity that were preserved by Shem and Ever.<sup>271</sup> He had begun to observe these teachings, which God would later give to his descendants as the Torah. Nonetheless, he did not circumcise himself, because this would have violated God's explicit commandment not to shed human blood;<sup>272</sup> his voluntary assumption of the Torah's commandments did not have the legal power to override an explicit directive.<sup>273</sup>

**32 All of Terach's days came to 205 years, and Terach died in Charan** in the year 2083. But because he was outwardly an idolater, he was considered figuratively "dead" even while he was alive, for the wicked are considered dead even in their lifetimes, whereas the righteous are considered alive even after their death.<sup>274</sup>

The *Haftarah* for *parashat Noach* may be found on p. 337.



<sup>270</sup>. *Likutei Sichot*, vol. 15, p. 202, note 23. <sup>271</sup>. Above, 11:17. <sup>272</sup>. Above, 9:5. <sup>273</sup>. *Likutei Sichot*, vol. 5, pp. 145-147. <sup>274</sup>. See 2 Samuel 23:20.



## Haftarah for Noach

Isaiah 54:1-10

Just as the Flood, chronicled in *parashat Noach*, cleansed the world from the cumulative negative effects of humanity's wrongdoing and prepared the world for a new order, the exile of the Jewish people is meant to cleanse them from the effects of their misdeeds and prepare them for the new order of the messianic Redemption. The comparison is made literally in v. 9.

54:1 In this prophecy, God speaks to the Jewish people after they have been exiled. **Sing, O barren Jerusalem, you who feel as though you have never given birth; break into a song of praise and be jubilant, you who feel as though you have never been in labor; for I assure you that the children of the abandoned one, the Jewish people, shall be more numerous than the children of the married wife, i.e., Edom, says God.** 2 Broaden the site of your tent, and let the curtains of your habitations be stretched out; be not sparing; lengthen your tent's anchor ropes, and secure your tent pegs. 3 For you will expand to the right and to the left, until your descendants dispossess nations and populate desolate cities. 4 Do not fear, for you will not be ashamed; do not be confounded, for you will not be disgraced; for you will forget the shame of your youth, and you will remember the reproach of your widowhood no more.

5 For your Maker is your husband, God of Hosts is His name. The Holy One of Israel is your redeemer; He will be called the God of the whole earth. 6 For God called you back like a wife abandoned by her angered husband, and grieved in spirit.

Can the wife of one's youth be rejected?

says your God. 7 For a brief moment I forsook you, but with great compassion will I gather you in. 8 With a little wrath, for a moment, I hid My face from you, but with everlasting kindness I will have compassion on you, said God, your redeemer.

9 For this promise to Me is like the promise I made concerning the waters of Noah's flood: just as I swore that the waters of Noah would never again submerge the earth, so have I sworn that I will not be wrathful with you and will not rebuke you. 10 For even if the mountains move and the hills falter, i.e., even if the merit of the patriarchs and matriarchs is exhausted, My kindness will not depart from you, nor will My covenant of peace ever falter, says God, who has compassion on you.

54:1 רָנִי עֲקָרָה לֹא יִלְדָה פְּצָחֵי רָנָה וְצִחְלֵי  
לֹא-חָלְלָה כִּי-רָבִים בְּנֵי-שׁוֹמְמָה מִבְּנֵי בְּעוּלָה  
אָמַר יְהוָה: 2 הֲרַחֲבִי אֶמְקוֹם אֹהֶלְךָ וִירֵיעוֹת  
מִשְׁכְּנֹתֶיךָ וְיָסוּ אֶל-תַּחֲשֻׁכַי הָאֲרִיכִי מִיַּתְרֶיךָ  
וַיִּתְדֶיךָ תִּזְקֵן: 3 כִּי-יִזְמִין וּשְׂמֹאוֹל תִּפְרָצֵי  
וְזָרְעֶךָ גּוֹיִם יִירָשׁוּ וְעָרִים נְשֻׁמוֹת יוֹשְׁבוֹ: 4 אֶל-  
תִּירְאִי כִּי-לֹא תִבְוָשִׁי וְאֶל-תִּכְלָמִי כִּי לֹא  
תִחַפְּרִי כִּי בָשַׂת עַל-זִמְנֶיךָ תִּשְׁפָּחִי וְהִרְפַּת  
אֶלְמִנּוֹתֶיךָ לֹא תִזְכְּרִי-עוֹד: 5 כִּי בְעַלְיֶךָ עִשְׂיֶיךָ  
יְהוּה צְבָאוֹת שָׁמָּו וְגֵאלְךָ קְדוֹשׁ יִשְׂרָאֵל אֱלֹהֵי  
כְּלֵה-אֲרָץ יִקְרָא: 6 כִּי-כִאֲשֶׁר עָזוּבָה וְעֵצוּבַת  
רוּחַ קְרָאָךָ יְהוּה וְאִשֶׁת נְעוּרִים כִּי תִמְאֵס  
אָמַר אֱלֹהֶיךָ: 7 בְּרַגַע קָסַן עֲזַבְתֶּיךָ וּבְרַחֲמִים  
גְּדַלְתִּים אֶקְבָּצֶךָ: 8 בְּשֹׁעַף קָצָף הִסְתַּרְתִּי פָנַי  
רַגַע מִפְּנֶיךָ וּבְחֶסֶד עוֹלָם רַחַמְתֶּיךָ אָמַר גֵּאלְךָ  
יְהוָה: 9 כִּי-יָמִי נָחָז אִתִּי לִי אֲשֶׁר נִשְׁפַּעְתִּי  
מִעֵבֶר מִי-נָח עוֹד עַל-הָאָרֶץ כֵּן נִשְׁפַּעְתִּי  
מִקָּצָף עָלֶיךָ וּמִגֶּעֶר-כָּדָ: 10 כִּי הִהְרִים לְמוֹשׁוֹ  
וְהִגְבְּעוֹת תְּמוֹטֶינָה וְחֻסְדֵי מֵאֲתָךָ לֹא-יִמוּשׁוּ  
וּבְרִית שְׁלוֹמִי לֹא תִמוּט אָמַר מְרַחֵמְךָ יְהוָה:



*Dedicated in honor of our children*

**Nathan, Yitzchok,  
Moshe Lev,  
and Gilana**

*May you continue to grow in the ways  
of our holy Torah*

**Yuri and Deana Pikover**

